



**AFCEA Belvoir PEO Industry Days**

Gaylord National Resort & Convention Ctr (Prince George Exhibits) - National Harbor, MD

November 17 - 18, 2020

Event Code: M145781120  
 email: [baltimore@shepardes.com](mailto:baltimore@shepardes.com)  
 phone: (410) 737-9270  
 fax: (410) 737-9274  
 mail: 7079 Oakland Mills Rd, Columbia, MD 21046

**BOOTH PACKAGE**

Items provided in your booth, per exhibitor:

- 8' High backwall drape, 3' High sidewall drape
- 7" x 44" Cardstock Identification Sign
- (1) 6' x 30" Skirted Table - Blue
- (2) Side Chairs
- (1) Wastebasket

Show drape color(s): Blue, White  
 Aisle carpet color: Eclipse

**Exhibit Show Schedule**

<b>General Exhibitor Move-in:</b>	Monday, November 16, 2020	1:00 PM	to	5:00 PM	
<b>Exhibit Hours:</b>	Tuesday, November 17, 2020	10:30 AM	to	7:00 PM	
	Wednesday, November 18, 2020	9:00 AM	to	2:00 PM	
<b>Exhibitor Move-out:</b>	Wednesday, November 18, 2020	2:00 PM	to	4:00 PM	
<b>Freight Reroute Begins*</b>	Wednesday, November 18, 2020	4:00 PM			*All outbound carriers must be checked in by this time

**Shipping Addresses**

See Material Handling Rate Form for all related fees.

**Advance Shipments Address**

[Exhibiting Co. Name & Booth Number]  
 AFCEA Belvoir PEO Industry Days  
 c/o Shepard Exposition Services  
 7079 Oakland Mills Rd  
 Columbia, MD 21046

**Direct Shipments Address**

c/o Shepard Exposition Services  
 [Exhibiting Co. Name & Booth Number]  
 AFCEA Belvoir PEO Industry Days  
 Gaylord National Resort & Convention Ctr (Prince George Exhibits)  
 701 Waterfront Street  
 National Harbor, MD 20745

**Important Deadlines**

- Discount price deadline for custom Shepard rentals: Monday, October 19, 2020
  - Exhibitor appointed contractor notification deadline: Monday, October 19, 2020
  - First day for warehouse deliveries without a surcharge: Monday, October 19, 2020
  - Discount price deadline for standard Shepard orders: Tuesday, October 27, 2020
  - Last day for warehouse deliveries without a surcharge: Monday, November 9, 2020
  - Last day for warehouse deliveries\*: Friday, November 13, 2020
- Date indicated is last day freight can arrive to advanced warehouse with guarantee of delivery to booth for exhibitor move-in.*
- First day freight can arrive at show facility: Monday, November 16, 2020

**AFCEA Belvoir PEO Industry Days**

Gaylord National Resort &amp; Convention Ctr (Prince George Exhibits) - National Harbor, MD

November 17 - 18, 2020

**Discount Deadline** Tuesday, October 27, 2020

Event Code:	M145781120
email	<a href="mailto:baltimore@shepardes.com">baltimore@shepardes.com</a>
phone	(410) 737-9270
fax	(410) 737-9274

**Shepard Mailing Address** 7079 Oakland Mills Rd, Columbia, MD 21046

**Due to liability concerns and/or labor jurisdictions, exhibitors or their EACs may not operate any type of mechanical or powered equipment including forklifts, electric pallet jacks, overhead lifts, etc.**

**Service Desk Hours** (subject to change)

Monday, November 16, 2020	1:00 PM	to	5:00 PM
Tuesday, November 17, 2020	10:30 AM	to	7:00 PM
Wednesday, November 18, 2020	9:00 AM	to	4:00 PM

**Exhibitor Move Out**

Wednesday, November 18, 2020 2:00 PM to 4:00 PM

**Dismantle & Move out Information**

Shepard will begin returning empty containers and skids as soon as the aisle carpet is removed from the floor. All exhibitor materials must be removed from the facility by Wednesday, November 18, 2020 4:00 PM. Any materials remaining in the hall will be rerouted or returned to Shepard's warehouse to await disposition at the exhibitor's expense.

To ensure all exhibitor materials are removed from the facility during the exhibitor move out, please have all carriers checked in with Shepard no later than Wednesday, November 18, 2020 4:00 PM

**Post Show Paperwork & Labels**

Our Customer Service Representatives will gladly assist you in preparing your outbound shipping labels, outbound Material Handling Authorization paperwork, and outbound shipping in advance. You may find these forms included in this exhibitor services catalog. An email with links to an online portal will also be sent to the exhibitor contact on record for the booth. Labels and paperwork will also be available onsite. Make sure your carrier knows your company name, booth number, and the carrier check in deadline.

**Outbound Shipping**

It is the responsibility of each exhibitor to arrange for transportation of booth materials after the event. Our Customer Service Representatives are available pre show, during the show, and during move out to assist you in arranging shipping through our official carrier Shepard Logistics. For peace of mind and easy set up, contact Shepard Logistics before the event for transportation services to and from the event.

Shepard does not provide UPS, FED-EX, or other carrier specific labels. Exhibitors must schedule pick ups directly with all carriers as well as provide carrier specific shipping labels.

**Pick Up Address**

Gaylord National Resort & Convention Ctr (Prince George Exhibits)  
701 Waterfront Street  
National Harbor, MD 20745

Move Out times and procedures may change due to show site and operational conditions. Move out information will be provided on site during the event.

**AFCEA Belvoir PEO Industry Days**

Gaylord National Resort &amp; Convention Ctr (Prince George Exhibits) - National Harbor, MD

November 17 - 18, 2020

Event Code:	M145781120
email	<a href="mailto:baltimore@shepardes.com">baltimore@shepardes.com</a>
phone	(410) 737-9270
fax	(410) 737-9274

## Online Ordering is Easy!

**Go to:** [www.shepardes.com/intro.asp](http://www.shepardes.com/intro.asp)**CLICK ON** AFCEA Belvoir PEO Industry Days**Login** from the Show Information page by clicking  at the top right corner of the page.**Enter** your email address and password then click 

**NEW users:** User name = Your Email Address (provided by Event Management)  
Password = AFCEA20

**Prior users:** User name = Your Email Address  
Password = Your pre-existing password

Don't remember your password? Click the link [Forgot your password?](#) and follow the prompts to have your password sent to the registered email address.

Once logged in, please confirm your profile information. If you need to update your information, please contact us at [customerservice@shepardes.com](mailto:customerservice@shepardes.com)

To order, utilize the grey category dropdown menus above the Welcome message.

After making your selections, click the  button on the bottom right of the page.

To view your order click the  Shopping Cart Icon at the top right of the page.

Confirm your order, click  and complete the payment process.

- \* Material Handling estimates will not be charged until freight is received at the warehouse or at show site.
- \* Labor and Hanging Sign estimates will not be charged until services are rendered at show site.

If you need assistance during your shopping experience, contact us using our  feature on the right side of the screen. Representatives are available Monday through Friday 8am - 5pm est.

### QUESTIONS?

We love to help! Contact us!

**Shepard Customer Service**

**(410) 737-9270**

[baltimore@shepardes.com](mailto:baltimore@shepardes.com)



AFCEA Belvoir PEO Industry Days

Gaylord National Resort & Convention Ctr (Prince George Exhibits) - National Harbor, MD

November 17 - 18, 2020

Event Code: M145781120
email: baltimore@shepardes.com
phone: (410) 737-9270
fax: (410) 737-9274
mail: 7079 Oakland Mills Rd, Columbia, MD 21046

Please complete the information and return this form with your orders. You may choose to pay by credit card, check payable to Shepard Exposition Services, or bank wire transfer, however, we require your credit card authorization to be on file before we process your order(s) for service. For your convenience, we will use this authorization to charge your credit card account for any additional amounts incurred as a result of show site orders placed by your representative including material handling and logistics charges for shipments received on your company's behalf and any unpaid balance due for Shepard services. Credits for services will be issued at show site only.

Once a payment is processed by credit card, any changes to the payment method will be charged a fee of 5% of the total invoice, 10010-Change Of Payment Method Transaction Fee

Please complete the following information:

Exhibiting Company Information

Company Name: \_\_\_\_\_ Booth #: \_\_\_\_\_
Street Address: \_\_\_\_\_ Phone: \_\_\_\_\_
City, St, Zip: \_\_\_\_\_ Fax: \_\_\_\_\_
Contact Name: \_\_\_\_\_
Email: \_\_\_\_\_

Credit Card Information

(Required for all forms of payment)

Check Wire Transfer



You may choose to pay by Check or Wire Transfer, however a credit card is required on file to process all orders.

Credit Card #: \_\_\_\_\_
Expiration Date: Month \_\_\_\_\_ Year \_\_\_\_\_ Security Code \_\_\_\_\_
Billing Address: \_\_\_\_\_
City, ST, Zip: \_\_\_\_\_
Name on Card: (Please Print) \_\_\_\_\_

Signature: \_\_\_\_\_

By signing the above I acknowledge and understand that ALL services rendered, including Material Handling and Logistics, will be billed to this credit card.

Wire Transfers

In order to accurately process the transfer of funds from your account, please complete the following information and fax it along with a copy of the wire receipt to the fax number printed on the header of this page. A \$50 service charge will be added for processing checks drawn on foreign banks. A \$25 service charge will be added for processing U.S. wire transfers. \$50 service charge for international wire transfers.

The following information must be included on the bank copy of the wire transfer confirmation:

Name of show that you are attending: AFCEA Belvoir PEO Industry Days
Exhibiting Company Name: \_\_\_\_\_
Booth Number: \_\_\_\_\_
Account Name: Shepard Exposition Services, Inc. Bank Name: PNC Bank N.A., Pittsburgh, PA 15219 USA
Routing Number: 041000124 Account Number: 42-6061-9772
SWIFT CODE (US): PNCCUS33 SWIFT CODE (INTL PNCCUS33)

Please include the show name, event code and your booth # as well as the wire fee if you are sending a wire transfer, ACH payment, or check.

TAX EXEMPT? Please submit tax exemption certificate to: baltimore@shepardes.com

If you are tax exempt, you must provide a tax exemption certificate for the state in which the event is being held.

You are entering a contract which limits your possible recovery in case of loss or damage.

The terms and conditions set forth below become a part of the contract between Shepard Exposition Services, and you, the Exhibitor. Exhibitor is deemed to accepted these terms and conditions when any of the following conditions are met:

Exhibitor materials are delivered to the Shepard warehouse or to a show or exposition site for which Shepard is the Official Show Contractor, or an order for labor and/or rental equipment is placed by the exhibitor with Shepard.

**Definitions and Shepard Responsibilities:** The name "Shepard" shall be construed within the meaning of this contract as Shepard Exposition Services, Inc. and its employees, officers, agents, and assigns including any subcontractors Shepard may appoint. The term "EXHIBITOR" refers to any party who contracts for services with Shepard. Shepard shall be responsible only for those services which it directly provides, and hereby agrees to execute its contracted duties in good faith. Shepard assumes no responsibility for any person, parties, or other contracting firms not under Shepard's direct supervision and control. Shepard shall not be responsible for loss, delay, or damage due to strikes, lockouts, work stoppages, natural elements, vandalism, acts of God, civil disturbances, power failures, acts of terrorism or war, or any other causes beyond Shepard's reasonable control; or for ordinary wear and tear in the handling of materials. Due to the security and liability requirements, Shepard personnel will unload all vendor materials from the loading docks to the booths. Exhibitors may not utilize powered mechanical equipment.

**Indemnification:** The exhibitor agrees to indemnify, forever hold harmless, and defend Shepard and its employees, officers and agents from and against any and all claims, causes of action, fines, penalties, damages, liabilities, judgments, and expenses on account of personal injury or death, damage to or loss of property or profits arising out of, or contributed to by any of the following: (1) exhibitor's negligent supervision of any labor secured through Shepard or the negligent supervision of such labor by any of the exhibitor's employees, agents, representative, invitees, and/or exhibitor appointed contractor (EAC); (2) exhibitor's negligence, willful misconduct, or deliberate act, or such actions of exhibitor's employees, agents, invitees, representatives, or EACs at the show to which this contract relates, including but not limited to the misuse, improper use, unauthorized alteration, or negligent handling of Shepard equipment; or (3) exhibitor's violation of Federal, State, or Local ordinance; or violation of show regulations and/or rules as published by the Facility and/or Show Management.

**Payments** are due prior to delivery of services or equipment to EXHIBITOR unless other credit arrangements have been made. All payments shall be in U.S. currency, MasterCard, VISA, or American Express, debit cards, or check, provided there is sufficient customer credit in Exhibitor's form of payment to completely satisfy the amount owed by EXHIBITOR to Shepard. Undersigned authorizer acknowledges and agrees that all applicable charges for services rendered to the EXHIBITOR will be applied to the credit card on file in the event other form of payment is not tendered prior to the close of the trade show. In no instance shall any Exhibitor be extended credit beyond 30 days after the close of the Show. If there are any outstanding balances owed by EXHIBITOR to Shepard which have not been paid after 30 days following the close of the Show, then these unpaid balances shall bear interest at the rate of 1-1/2% per month (18% per annum). Exhibitor will be responsible for all charges incurred by Shepard while endeavoring to collect this account. If EXHIBITOR provides a credit card for payment and the credit card transaction is declined, EXHIBITOR hereby authorizes Shepard to process the outstanding balance in multiple smaller increments that total the amount of the outstanding payment obligation. In the event that a THIRD PARTY (AGENT) orders on behalf of the EXHIBITOR and the named THIRD PARTY does not discharge payment of the invoice prior to the last day of the show, charges will revert back to the EXHIBITOR. All invoices are due and payable upon receipt, by either party

**Show Site Orders:** Services ordered at show site will require full payment at the time the order is placed. Purchase orders may not be used in lieu of payment. Regular prices will apply to all show site orders. Floor orders are limited to availability.

**Third Party Orders:** If you contract your work to a display or exhibit house and require services from Shepard, the payment policy stated above applies. Please pass this information on to them. A Third Party Payment form must be completed and submitted three weeks prior to show opening.

**Equipment Audits:** EXHIBITOR should be advised that routine audits of Exhibitor booths for service usage are conducted during the Convention. Should the result of such an audit indicate that equipment or services is in fact being used that has not been paid for, the Exhibitor will be charged for the equipment or service at the applicable rate.

**Exchanges and Cancellations:** Onsite exchanges and cancellations in orders will be assessed a 100% pick-up fee. Custom products: All orders cancelled by the exhibitor within 30 days of first day of exhibitor move in day may be subject to cancellation fees up to 100% of the total order, based upon the status of move-in, work performed and/or Shepard set-up costs or expenses. Equipment and Furnishings: There are no exchanges or refunds once item has been delivered to your booth. Cancellations must be received in writing within 14 days prior to first exhibitor move in day. Labor: Cancellations must be received in writing before 48 hours of 1st day of exhibitor move in, otherwise a 1 hour per man ordered will apply.

**Invoices:** Prior to close of show, an invoice will be prepared and emailed to the booth contact on file for your review. Credits will be issued at show site only. If you have any questions or want to pay your invoice by check or cash, please see our customer service representatives at the service desk on site.

**Outbound Services:** All outbound services will be processed on your credit card. A copy of the receipt and invoice will be mailed within 10 days of the close of the show.

**Rental Responsibility:** All materials are on a rental basis and shall remain the property of Shepard. The customer shall be held financially responsible for any damage to Shepard equipment used by the customer. Prices quoted are for the duration of the show and include installation, rental, and removal except where indicated. If skirting and carpet colors are not selected, show colors will prevail.

**International Customers:** International customers must pay for all services in U.S. funds. A \$50 service charge will be added for processing checks or wire transfers drawn on foreign banks.

**U.S. Wire Transfers:** A \$25 service charge will be added for processing U.S. wire transfers. Please complete the wire transfer portion of the Payment Authorization form. The credit card portion of the form must still be completed before your order will be processed.

**Tax Exempt Status:** If you are tax exempt in the state where the show is held, a copy of the certificate must accompany your order.

**Tax Rates:** State tax regulations and tax rates can change after the date of publication. Prevailing state tax rates will supersede any published rate

**Exhibitor Information:** Exhibitor permits all contact information provided to Shepard to be used by Shepard and shared with other entities assisting in the production of the event in question. Facsimiles and email communications may include show information, promotional materials, advertising statements and other commercial notices. Permission may be revoked by the EXHIBITOR in writing.

**Cancellation or Event Postponement:** In the event the exposition or event is cancelled or postponed, Shepard reserves the right to charge for services rendered in preparation of the event or exposition as well as non-refundable costs incurred by Shepard.

**Insurance:** It is understood that Shepard is not an insurer. Insurance should be obtained by the EXHIBITOR. It is highly recommended that exhibitors arrange All Risk coverage which usually can be done by endorsements to existing policies. Exhibitor's materials should be insured from the time they leave their firm until they are returned after the close of the show. Insurance and liability against theft or property damage to equipment or exhibit material owned or rented by EXHIBITOR, or bodily injury occurring within the confines of Exhibitor's booth, remain the sole and complete responsibility of EXHIBITOR. Except where prohibited by law, the EXHIBITOR and its insurers waive all rights of recovery or subrogation against Shepard and their respective directors, officers, employees, and agents.

**Claim(s) for Loss and Payment For Services:** Exhibitor agrees that any and all claims for loss or damage shall be submitted to Shepard prior to the conclusion of the show when the alleged loss or damage occurred prior to that time, and in all cases within 30 days of the conclusion of the show. For claim reporting purposes, the "conclusion" of the show shall be construed as the end of the day on which exhibitor must vacate the show site. All claims reported after the 30-day period will be rejected. In no event shall a suit or action be brought against Shepard more than one year after the date the loss or damage occurred. Payment for services may not be withheld. In the event of any dispute between Shepard and the exhibitor relative to any loss or damage claim, the exhibitor shall not be entitled to and shall not withhold payment for Shepard services as an offset against the amount of the alleged loss or damage. Any claim against Shepard shall be considered a separate transaction and shall be resolved on its own merit.

**Limits of Liability:** If found liable for any loss, Shepard's sole and exclusive maximum liability for loss or damage to Exhibitors materials and Exhibitor's sole and exclusive remedy is limited to \$.50 (USD) per pound per article with a maximum liability of \$100.00 (USD) per item, or \$1,500.00 (USD) per shipment whichever is less. All shipment weights are subject to correction and final charges determined by the actual or re-weighed weight of the shipment. Shepard shall in no event be liable for collateral, exemplary, indirect costs or damages, or loss of sales resulting from, or related to, a claim for loss of or damage to material.

**Inbound and Outbound Shipments:** Consistent with trade show industry practices, there may be a lapse of time between the delivery of shipment(s) to the booth and the arrival of the exhibitor or his representative. During such time, the materials will be left unattended. Shepard is not, and cannot be, responsible for loss, damage, theft, or disappearances of exhibitor's materials after same have been delivered to the exhibitor's booth. Similarly, there may be a lapse of time between the completion of packing and the actual pick up of exhibitor's materials from the booth for loading onto a carrier. During such time, the materials will be left unattended. Shepard shall not be responsible for loss, damage, theft, or disappearance of exhibitor's materials before same have been picked up for loading after the show. All materials will be checked at the booth at the time of loading using document(s) submitted by the exhibitor and notations of exceptions to conditions of materials or piece counts will be made on said document. Shepard assumes no responsibility for loss, damage, theft, or disappearance of exhibitor's materials after same have been delivered to exhibitor's appointed carrier or agent for transportation after the show. Shepard loads materials onto the carrier's truck under the supervision of the carrier driver who checks and signs for the materials. Shepard assumes no liability for any materials after the carrier assumes custody of materials. If exhibitor's designated carrier fails to show by the move out deadline after a show, Shepard shall have the authority to route exhibitor's shipment via an alternate carrier, or return shipment to a local warehouse for disposition at exhibitor's expense.

**Packaging, Crates, and Empty Containers:** Shepard shall not be responsible for surface damage to loose or uncrated materials, pad-wrapped, or shrink-wrapped materials. Shepard shall not be responsible for concealed damage, damage to carpets in bags or poly, or damage to materials improperly packed. Shepard shall not be responsible for crates and packaging unsuitable for handling, partially assembled, or having prior damage. Affixing "Empty" storage labels to containers is the sole responsibility of the exhibitor or their representative. All previous labels should be removed. Shepard assumes no responsibility for removal or mis delivery of containers with old labels or incorrect information on labels or for loss or damage to materials stored in containers labeled "empty."



# 3rd Party Payment Authorization

## AFCEA Belvoir PEO Industry Days

Gaylord National Resort & Convention Ctr (Prince George Exhibits) - National Harbor, MD

November 17 - 18, 2020

**Deadline** **Monday, October 19, 2020**

Return this form when a third party (any party other than exhibiting company) should be billed for services.

Event Code:	M145781120
email	<a href="mailto:baltimore@shepardes.com">baltimore@shepardes.com</a>
phone	(410) 737-9270
fax	(410) 737-9274

Both parties MUST sign this form indicating acceptance; otherwise, request will be denied.  
 When a third party is handling your display and/or paying for any services on your behalf, we will agree to this third party arrangement if the following payment is agreed upon and all signatures are properly completed.  
 By signing this form, both parties agree and understand that the exhibiting firm is responsible for all charges.  
 In the event that the named third party does not make payment by show close, Shepard will be paid by the exhibiting firm on demand at show site.  
 The show site invoice may or may not include any outbound services, such as additional material handling, rigging, and/or shipping charges.

### Step 1: Provide the Exhibiting Company Contact Information and Signature

Exhibiting Company Name: \_\_\_\_\_ Booth #: \_\_\_\_\_

Exhibiting Company Address: \_\_\_\_\_

Phone: \_\_\_\_\_

Email Address: \_\_\_\_\_

Exhibiting Company Authorized Name - Please Print: \_\_\_\_\_

Signature from Exhibiting Company: \_\_\_\_\_

### Step 2: Check Services Below to Bill to the Third Party

All Services

Booth Cleaning   
  Carpet   
  Exhibit Rentals   
  Installation/Dismantling Labor   
  Logistics/Transportation  
 Material Handling   
  Furniture   
  Overhead Rigging/Labor   
  Other (please specify): \_\_\_\_\_

### Step 3: Provide Third Party Contact Information

3rd Party Company Name: \_\_\_\_\_

Contact Name: \_\_\_\_\_

Address: \_\_\_\_\_

Phone: \_\_\_\_\_ Email Address: \_\_\_\_\_

### Step 4: Complete Third Party Credit Card Charge Authorization with Signature

#### Credit Card Information

(Required for all forms of payment)



Credit Card #: \_\_\_\_\_

Expiration Date: Month: \_\_\_\_\_ Year: \_\_\_\_\_ Security Code: \_\_\_\_\_

Billing Address: \_\_\_\_\_

City, ST, Zip: \_\_\_\_\_

Name on Card: (Please Print) \_\_\_\_\_

Signature: \_\_\_\_\_



AFCEA Belvoir PEO Industry Days

Gaylord National Resort & Convention Ctr (Prince George Exhibits) - National Harbor, MD

November 17 - 18, 2020

Due By: Monday, October 19, 2020

Event Code: M145781120
email: baltimore@shepardes.com
phone: (410) 737-9270
fax: (410) 737-9274

This form is to be completed by the Exhibitor and returned to Shepard by deadline date noted above.

Exhibiting

Company Name

Booth #

Email Address:

An Exhibitor Appointed Contractor (EAC) is a company other than the "general or official" service provider on the show that requires access to your booth during installation and dismantling. The EAC may only provide services in the facility that are not designated by the facility as "exclusive" to a designated provider, or by the event organizer in a contract as an exclusive service for the "general or official: service provided or other third party.

No EAC will be allowed to work in an exhibitor's booth if this EAC form, a valid form of insurance, a third party payment authorization form and an exhibitor payment authorization is not completed by an authorized representative and received by Shepard by the due date indicated above. The Form must be completed for every third party (as well as any other ordering third party ordering or requesting services from Shepard on behalf of exhibitor) at the above event. Multiple booths are not to be listed on one form. If form is not submitted by deadline date, the EAC will not be allowed to perform work in the hall except to supervise the official contractor provided labor.

Exhibitor Appointed Contractor

Contact Name

Street Address

City

Phone #

Description of proposed service for Exhibitor

The EAC hired by the exhibitor must, by the deadline date, provide Shepard with a current Certificate of Insurance with minimum limits of \$500,000 property damage per occurrence, \$1,000,000 personal injury per occurrence, workers compensation aggregate coverage of \$1,000,000 per occurrence, and naming Shepard Exposition Services as the certificate holder for the time period of the event, including move-in and move-out days. Listing Shepard Exposition Services as an additionally insured only will not be accepted, and may prevent EAC from working on the premises. If EAC does not have minimum coverage and proper documentation, they will be subject to employing Shepard Exposition Services for labor services.

The EAC must abide by the rules and regulations of the show and all pertinent union regulations.

EAC employees must wear approved identification badges at all times while in the work area. Badge will be issued at show site to authorized contractor representatives when all requirements have been met.

The EAC must confine its operations to the exhibit area of its clients. No service desks, storage areas or other work facilities will be located anywhere in the facility. Show aisles and public areas are not part of the Exhibitor's booth space.

Solicitation of business by EAC is strictly prohibited. EAC companies discovered soliciting will be removed from the show floor and the exhibitor will not be able to use that EAC for the remainder of the event.

The EAC must have all business licenses, work permits and insurance required by State and City governments and Facility Management before beginning work, and shall provide Show Management with evidence of compliance.

If required, the EAC must be able to provide evidence that it has current and applicable labor contracts and must comply with all labor agreements and jurisdictions. The EAC must not jeopardize the production of the event by any act or practice that would lead to work stoppages, strikes or labor disputes.

EACs agrees to keep all No Freight Aisles clear at all times. If SES is required to rearrange any material situated in a clearly No Freight Aisle, the exhibitor or the EAC depending on billing arrangements will be a charged a 1 hour minimum forklift rental and labor.

Exhibitor Signature:



**AFCEA Belvoir PEO Industry Days**

Gaylord National Resort & Convention Ctr (Prince George Exhibits) - National Harbor, MD

November 17 - 18, 2020

Event Code:

M145781120

email

[baltimore@shepardes.com](mailto:baltimore@shepardes.com)

phone

(410) 737-9270

fax

(410) 737-9274

**Save Time and Money!**

Use this grid when placing Hanging Sign, Electrical, or other Utility Orders. Make as many copies as you need!

Company Name:

Booth #

\_\_\_\_\_

Contact Name

Contact Email Address

\_\_\_\_\_

Enter in the booth numbers above, below, and on each side of your booth to ensure proper placement!  
If you are using this grid for a hanging sign, include the total height from the floor to the top of the sign.

Above Booth #

Left Booth #

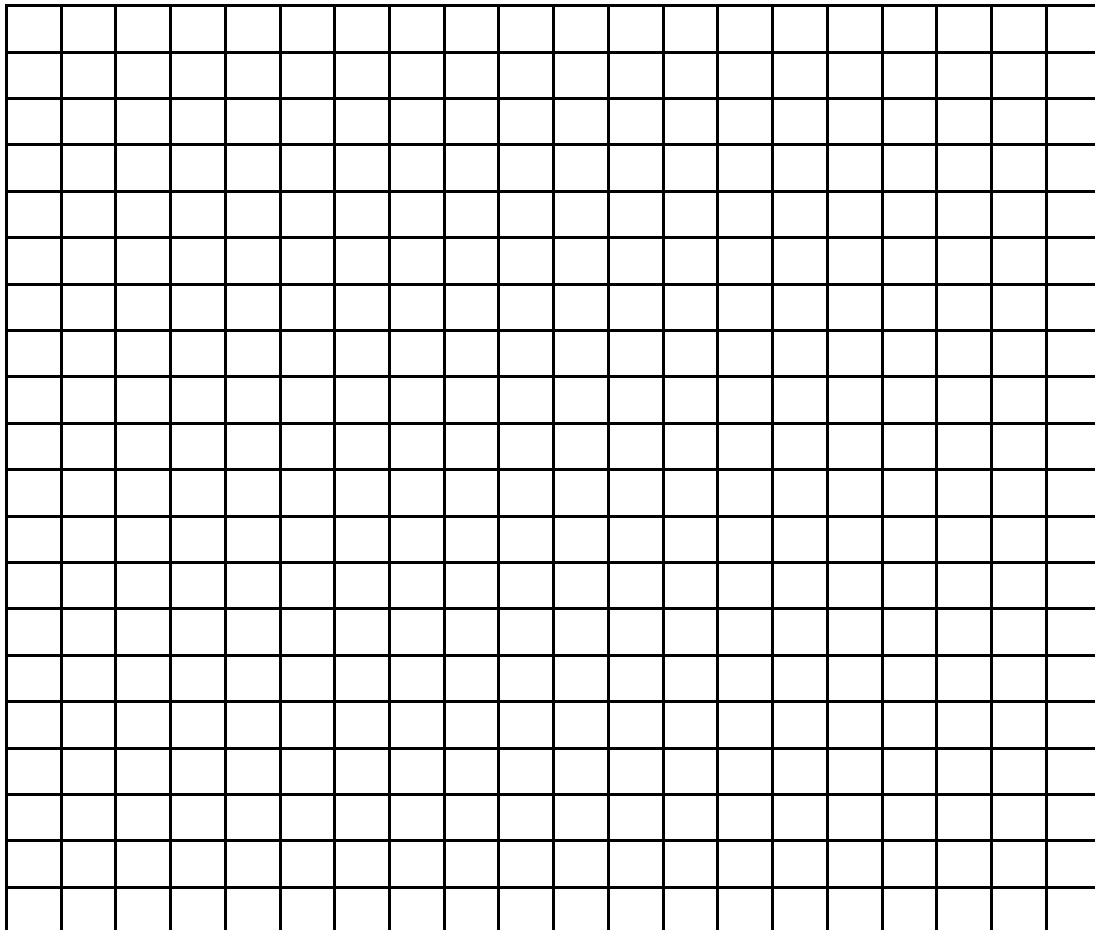

Right Booth #

Below Booth #





## *Relax with our Carefree Logistics!*

Shepard Logistics is the official show carrier. Our dedicated team of Logistics Specialists will provide you with personalized and efficient shipping solutions to make sure your freight arrives on time. We make shipping easy and convenient!

### **Inbound & Outbound Services**

- Small Package
- Standard Ground
- Next Day, 2nd Day, and 3rd Day Service levels
- Air Ride
- Flat Bed
- Dedicated Truckload

### **Shepard Value-Added Services**

- Priority empty return for all inbound Shepard Logistics customers
- Transparent quotes with no hidden charges such as reweigh or trade show fees
- Shepard Logistics available 7 days a week
- Late to Warehouse and Late to Show Site Fee waived
- Outbound shrink-wrap at no charge
- Signature Series Material Handling 10% discount to all roundtrip customers

### ***Have a Logistics Question?***

Visit Shepard Logistics in your Exhibitor Services Catalog or contact our Logistics team:

1.888.568.8858 | [logistics@shepardes.com](mailto:logistics@shepardes.com)



Exhibit  
Rental



Traffic  
Builders



Logistics &  
Transportation



Furniture  
Rentals



Material Handling  
& Ground Rigging



More!



# SHIPPING VERSUS MATERIAL HANDLING

## WHAT IS SHIPPING?

Shipping is the process of a carrier picking up your items from your office or place of origin and transporting it to the dock of either the advance warehouse or facility dock of your event. It is separate from Material Handling. Exhibitors may use any carrier they want, including Shepard Logistics.

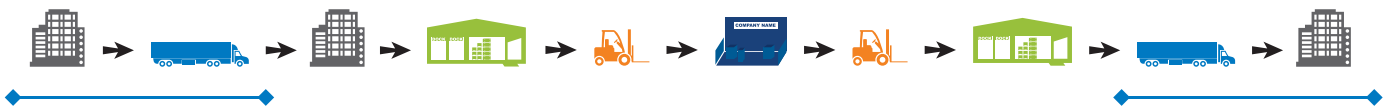

## WHAT IS MATERIAL HANDLING?

Material Handling is the process of receiving your shipment from your carrier and managing it through the event cycle. It is a standard tradeshow process and it is a chargeable fee typically based on the weight of your shipment. Don't forget to add Material Handling to your budget!



### Material Handling Process:

- Unloading the trade show freight from your carrier once it arrives at the receiving dock.
- Transporting your shipment to your booth space.
- Removing empty shipping containers (boxes, crates, and pallets) from your booth.
- Temporarily storing your empty shipping containers during the show.
- Returning empty shipping containers to your booth once the event is over.
- Transferring the freight back to the loading dock.
- Loading the items into your carrier's delivery vehicle for return shipping.

### ONE EASY WAY TO KEEP YOUR CHARGES LOWER?

#### Consolidate, Consolidate, Consolidate!

*Skid items as much as possible so that they are sure to arrive together. Each shipment that arrives at a separate time is assessed the minimum charge. Whether you ship to the advance warehouse or show site it is in your best interest to consolidate as much as possible.*



# Agility

*Fairs & Events*

**The experts in International Event Logistics**

Agility Fairs & Events is the preferred International Freight Forwarder and Customs Broker for Shepard Exposition Services events.

Our complete services include:

- Shipment planning—packaging, documentation, scheduling
- Door pick-up at the overseas origin
- International shipping and Customs clearance at US air/port
- Final delivery to the Shepard advance warehouse or show dock
- Pick-up at the show site dock or Shepard warehouse
- Preparation of export documents
- International shipping and Customs clearance overseas
- Final delivery to the overseas return destination

**Single point of contact  
for international shipping  
from door to door:**

Agility Fairs and Events  
1 100 Tamiami Trail S.  
Suite B  
Venice, FL 34285  
Tel: 941-861-8930  
Contact: Kelly O'Neill-Exley  
koneill@agility.com  
[www.agility.com/fairsevents](http://www.agility.com/fairsevents)  
[expousa@agility.com](mailto:expousa@agility.com)

**Get a free quote for international shipping at:  
[www.agility.com/en/contact-fairs-events](http://www.agility.com/en/contact-fairs-events)**



**[www.aglfairslogistics.com/usaebrochure/](http://www.aglfairslogistics.com/usaebrochure/)**



AFCEA Belvoir PEO Industry Days

Gaylord National Resort & Convention Ctr (Prince George Exhibits) - National Harbor, MD

November 17 - 18, 2020

Event Code: M145781120
email: logistics@shepardes.com
phone: (888) 568-8858
fax: (404) 596-5620

Ship Roundtrip with Shepard Logistics and receive a 10% discount on Material Handling\*

Discount does not apply to shipments considered small package, local deliveries, "Light Weight" shipments, or shipments over 10,000 lbs. Roundtrip SLS shipping is required to qualify for discount. (35572)

Step 1: Complete Exhibiting company information:

Exhibiting Company Name Booth #

Contact Name Phone # State Zip

Email Address

Step 2: Tell us the Location of items for pick up:

Company

Street Address City State Zip

- Is there a loading dock? Do we need a lift gate on our truck?
Is your building in a residential area? Do we need to go inside your office to pick up your items?
Any thing else we should know about your building

Step 3: Tell us When we are picking it up:

Date Hours of Operation

Step 4: Tell us Where this is going: Advance Warehouse

Step 5: Tell us What we are shipping:

Table with 2 columns for item types (Crates, Cartons, Cases/trunks, Skids/pallets and Carpet, Monitors, Other, Total) and 5 columns for dimensions (Qty, L, W, H, Weight).

Step 6: Tell us what Type of Service do you need (how fast do you need it?)

- Standard Ground 2nd day Air Next Day Air Other (Truckload, Specialized)

Service level may be changed to meet delivery date. Order must be received within 24 hours of requested pick up date

Step 7: After the event is over, are we going to Ship Back to you? YES! No, I will arrange another carrier

Company Booth #

Street Address City State Zip

A credit card must be on file to order Shipping Services. Please complete the Payment Authorization form. Shipping services do not include material handling charges at show site. Material handling fees will be charged to the credit card on file.



# Outbound Material Handling Authorization and Shipping Labels

## AFCEA Belvoir PEO Industry Days

Gaylord National Resort & Convention Ctr (Prince George Exhibits) - National Harbor, MD

November 17 - 18, 2020

**\$\$ Saving Tip! Use Shepard Logistics for inbound and outbound and receive a discount on your Material Handling fees!**

Event Code: M145781120  
email: baltimore@shepardes.com  
phone: (410) 737-9270  
fax: (410) 737-9274

All outbound shipments require a **Shepard Outbound Material Handling Authorization** form and shipping labels. Shepard offers complimentary pre-printing of these items. To take advantage of this service, please complete this request and submit to Shepard. Your pre-printed MHA and labels will be delivered to your booth prior to the close of the show. \*Note: All third parties must pick up MHA/labels at the Shepard Service Desk.

### Step 1: Complete Exhibiting Company Information:

Exhibiting Company Name	Booth #
Contact Name	Phone #
Email Address	

### Step 2: Tell us Where your items are going:

Company			
Street Address	City	State	Zip

### Step 3 How many Pieces are in your shipment?

\_\_\_\_\_ # of Crate    \_\_\_\_\_ # of Skids    \_\_\_\_\_ # of Cases    \_\_\_\_\_ # of Cartons    \_\_\_\_\_ Approx. Total Weight

### Step 4: Tell us What we are shipping:

Qty	L	W	H	Weight	Qty	L	W	H	Weight
<input type="checkbox"/> Crates	_____	_____	_____	_____	<input type="checkbox"/> Carpet (color)	_____	_____	_____	_____
<input type="checkbox"/> Cartons (cardboard)	_____	_____	_____	_____	<input type="checkbox"/> Monitors	_____	_____	_____	_____
<input type="checkbox"/> Cases/trunks	_____	_____	_____	_____	<input type="checkbox"/> Other	_____	_____	_____	_____
<input type="checkbox"/> Skids/pallets	_____	_____	_____	_____	<input type="checkbox"/> Total	_____	_____	_____	_____

- |  |  |
|--|--|
| <input type="checkbox"/> Is there a loading dock?                | <input type="checkbox"/> Do we need to go inside your office to pick up or deliver your items? |
| <input type="checkbox"/> Is your building in a residential area? | <input type="checkbox"/> Is there anything else we should know about your building?            |
| <input type="checkbox"/> Do we need a lift gate on our truck?    |  |

### Step 5: How many Labels do you need? \_\_\_\_\_

### Step 6: Who is picking up your shipment?

\_\_\_\_\_ OFFICIAL SHOW CARRIER: SHEPARD LOGISTICS    OTHER \_\_\_\_\_

If selecting a carrier other than Shepard Logistics, you must schedule the pickup. This includes Fed Ex, UPS, etc.

If using FedEx or UPS you must have *and apply* their shipping labels.

### Step 7: What type of Service do you need? (how fast does it need to get there?)

\_\_\_\_\_ Ground    \_\_\_\_\_ 2nd Day    \_\_\_\_\_ Exped. Ground (3-5 days)    \_\_\_\_\_ Overnight

### Step 8: If your carrier doesn't show up, what do we do with your items?

- \_\_\_\_\_ Reroute via the show carrier (Shepard Logistics)
- \_\_\_\_\_ Return to warehouse (\$400.00 minimum charge)

In order to process your order, we require payment on file. Please complete the Payment Authorization Form and return to Shepard Exposition Services. If you have already placed an order with Shepard, we will **automatically** use the credit card on file for your company.

Print at least one label for each box. Include the exhibiting company name and booth number. If you are creating your own labels, make sure the same information below is on your labels.

<b>R U S H</b>	
	<b>ADVANCE WAREHOUSE</b>
	TO: _____ (Exhibiting Company Name)
	Booth #: _____
	<b>c/o Shepard Exposition Services</b>
	<b>7079 Oakland Mills Rd</b>
	<b>Columbia, MD 21046</b>
	<b>Delivery Hours: M-F, 8-4:00 PM</b>
For: <b>AFCEA Belvoir PEO Industry Days</b>	
First day freight can arrive w/o a surcharge: <b>October 19, 2020</b>	
Last day freight can arrive w/o a surcharge: <b>November 9, 2020</b>	

<b>R U S H</b>	
	<b>ADVANCE WAREHOUSE</b>
	TO: _____ (Exhibiting Company Name)
	Booth #: _____
	<b>c/o Shepard Exposition Services</b>
	<b>7079 Oakland Mills Rd</b>
	<b>Columbia, MD 21046</b>
	<b>Delivery Hours: M-F, 8-4:00 PM</b>
For: <b>AFCEA Belvoir PEO Industry Days</b>	
First day freight can arrive w/o a surcharge: <b>October 19, 2020</b>	
Last day freight can arrive w/o a surcharge: <b>November 9, 2020</b>	

<b>R U S H</b>	
	<b>ADVANCE WAREHOUSE</b>
	TO: _____ (Exhibiting Company Name)
	Booth #: _____
	<b>c/o Shepard Exposition Services</b>
	<b>7079 Oakland Mills Rd</b>
	<b>Columbia, MD 21046</b>
	<b>Delivery Hours: M-F, 8-4:00 PM</b>
For: <b>AFCEA Belvoir PEO Industry Days</b>	
First day freight can arrive w/o a surcharge: <b>October 19, 2020</b>	
Last day freight can arrive w/o a surcharge: <b>November 9, 2020</b>	

<b>R U S H</b>	
	<b>ADVANCE WAREHOUSE</b>
	TO: _____ (Exhibiting Company Name)
	Booth #: _____
	<b>c/o Shepard Exposition Services</b>
	<b>7079 Oakland Mills Rd</b>
	<b>Columbia, MD 21046</b>
	<b>Delivery Hours: M-F, 8-4:00 PM</b>
For: <b>AFCEA Belvoir PEO Industry Days</b>	
First day freight can arrive w/o a surcharge: <b>October 19, 2020</b>	
Last day freight can arrive w/o a surcharge: <b>November 9, 2020</b>	

Print at least one label for each box. Include the exhibiting company name and booth number. If you are creating your own labels, make sure the same information below is on your labels.

**RUSH**

  
**DIRECT TO SHOW**

TO: \_\_\_\_\_  
(Exhibiting Company Name)

Booth #: \_\_\_\_\_

c/o Shepard Exposition Services  
Gaylord National Resort & Convention Ctr (Prince George Exhibits)  
701 Waterfront Street  
National Harbor, MD 20745

For: AFCEA Belvoir PEO Industry Days

**MUST NOT BE DELIVERED PRIOR TO:**  
November 16, 2020 @ 8:00 AM

**RUSH**

  
**DIRECT TO SHOW**

TO: \_\_\_\_\_  
(Exhibiting Company Name)

Booth #: \_\_\_\_\_

c/o Shepard Exposition Services  
Gaylord National Resort & Convention Ctr (Prince George Exhibits)  
701 Waterfront Street  
National Harbor, MD 20745

For: AFCEA Belvoir PEO Industry Days

**MUST NOT BE DELIVERED PRIOR TO:**  
November 16, 2020 @ 8:00 AM

**RUSH**

  
**DIRECT TO SHOW**

TO: \_\_\_\_\_  
(Exhibiting Company Name)

Booth #: \_\_\_\_\_

c/o Shepard Exposition Services  
Gaylord National Resort & Convention Ctr  
(Prince George Exhibits)  
701 Waterfront Street  
National Harbor, MD 20745

For: AFCEA Belvoir PEO Industry Days

**MUST NOT BE DELIVERED PRIOR TO:**  
November 16, 2020 @ 8:00 AM

**RUSH**

  
**DIRECT TO SHOW**

TO: \_\_\_\_\_  
(Exhibiting Company Name)

Booth #: \_\_\_\_\_

c/o Shepard Exposition Services  
Gaylord National Resort & Convention Ctr  
(Prince George Exhibits)  
701 Waterfront Street  
National Harbor, MD 20745

For: AFCEA Belvoir PEO Industry Days

**MUST NOT BE DELIVERED PRIOR TO:**  
November 16, 2020 @ 8:00 AM



# Material Handling Rates

## AFCEA Belvoir PEO Industry Days

Gaylord National Resort & Convention Ctr (Prince George Exhibits) - National Harbor, MD

November 17 - 18, 2020

Event Code: M145781120  
 email [baltimore@shepardes.com](mailto:baltimore@shepardes.com)  
 phone (410) 737-9270  
 fax (410) 737-9274

### Ship Roundtrip with Shepard Logistics and receive a 10% discount on Material Handling\*

Discount does not apply to shipments considered small package, local deliveries, "Light Weight" shipments, or shipments over 10,000 lbs. Roundtrip SLS shipping is required to qualify for discount. (35572)

### What is Material Handling?

Material Handling is the unloading and delivery of exhibit freight to the exhibitor's booth on the show floor, the storage of empty containers, the return to booth for packing, and the loading back onto the exhibitor's outbound carrier. This is an automatic service and is billed based on weight. This service, whether used completely or in part, are billed as a package.

**How to Calculate Material Handling Services:** The following services whether used completely or in part are offered as a package. When estimating weight, round up to the next 100 lbs. For example: 285 lbs. = 300 lbs./100 lbs. = 3 X RATE = \$ Amount or minimum charge, whichever is greater.

**Standard Material Handling Rates:** All rates are per 100 pounds with a 200 pound minimum charge. Certified weight tickets are required on all shipments.

**Blended Rates:** The rates stated are blended to include overtime based on the schedule at publication. Changes in schedule or if your carrier delivers your freight outside of published hours may result in additional fees. Please see Material Handling page for a complete listing of all possible charges.

### Important! All Material Handling fees will be automatically billed to the credit card on file!

### Advance Warehouse Shipments

First date freight can arrive Monday, October 19, 2020

Last date freight can arrive Friday, November 13, 2020

Item	Code	Weight		Price	Total
Crated	35010	_____	x	\$126.00	_____
Special Handling	35036	_____	x	\$163.75	_____

Single pieces over 5000 pounds, machines or uncrated items cannot be accepted at warehouse.

### Direct to Showsite Shipments

First date freight can arrive Monday, November 16, 2020

Item	Code	Weight		Price	Total
Crated	35030	_____	x	\$114.60	_____
Uncrated	35043	_____	x	\$172.00	_____
Special Handling	35038	_____	x	\$149.00	_____

Large pieces of machinery and uncrated shipments can be accepted at showsite.

### Light Weight (Shipments 40 pounds or less)

Item	Code	Weight		Price	Total
Light Weight Shipment	35400	_____	x	\$63.00	_____

### Other Material Handling Services

Banding Service per 4x4 skid/pallet	35490	Qty _____		\$75.00
Shrink-wrap Service per 4x4 skid/pallet	35491	Qty _____		\$75.00

### Only Shepard personnel are allowed to operate mechanical equipment.

We understand that your calculation is only an estimate. Invoicing will be calculated from actual certified weight ticket or reweigh ticket on inbound material handling receiving report. Adjustments will be made accordingly. Any adjustments to charges must be made at show site. Acceptance of said terms and conditions will be construed when any of the following conditions are met: This Material Handling Agreement (MHA) is signed; Exhibitor's materials are delivered to Shepard's warehouse or to an event site for which Shepard is the Official Show Contractor or an order for labor and/or rental equipment is placed by Exhibitor with Shepard. Please be aware that disposal of exhibit properties is not included as part of your material handling charges. Please contact Shepard for your quoted rates and rules applicable to disposal of your exhibit properties.

All Material Handling charges are billable and will be charged to the credit card on file.

Company Name: \_\_\_\_\_ Booth # \_\_\_\_\_

Contact Name \_\_\_\_\_

Email: \_\_\_\_\_

Signature: \_\_\_\_\_



## AFCEA Belvoir PEO Industry Days

Gaylord National Resort & Convention Ctr (Prince George Exhibits) - National Harbor, MD

November 17 - 18, 2020

Event Code: M145781120  
 email: [baltimore@shepardes.com](mailto:baltimore@shepardes.com)  
 phone: (410) 737-9270  
 fax: (410) 737-9274

### Special Handling Definitions Rate as shown on Material Handling Rate Form, approx. 30%

Shipments received that are packed in a manner as to require additional handling/labor are deemed special handling. Examples of shipments falling into this category would be constricted space unloading, ground unloading, stacked shipments, designated piece unloading, shipment integrity, mixed shipments, no bill of lading or documentation, carpet/pad only shipments.

- Constricted Space - Freight packed in trailer to full capacity. Shipments are not easily accessible because trailer is loaded by cubic space, or top to bottom and side to side.
- Stacked Shipments - Shipments with multiple pieces stacked on top of one another throughout the majority of the truck or trailer requiring unstacking during the unloading process.
- Mixed Shipments - Mixed shipments are shipments that contain a mixture of uncrated and crated materials, and the uncrated portion is minimal deeming the shipment special handling but not uncrated. But in cases where greater than 50% of the load by volume is uncrated the load will be categorized as uncrated.
- Shipment Integrity - Shipments loaded on a carrier in a manner requiring separating or sorting to reestablish the integrity of each shipment.
- Carpet/Pad Only - Carpet and/or pad only shipments are time and labor intensive, and require additional manpower and tools (e.g. carpet poles, flatbed carts or scooters, dollies).
- No Documentation - Shipments received from small package carriers (including, among others, Fed Ex, UPS, & DHL) that are delivered without documentation or bills of lading that require additional sorting, processing, and tools for delivery.
- Designated Piece Unloading - Shipments loaded in such a manner that require the unloading/loading crew to be directed by driver remove items in a particular order, or unloading and reloading items to reach certain pieces behind others remaining on the trailer.

**Padded Van Deliveries** This applies to van line carriers that transport freight at cubic displacement rates, operate a non-standard dock height equipment, require freight on the truck to be unloaded in a specific order or orientation, or require that freight on the truck be moved to unload the actual delivery.

### Disposal Fee

A disposal fee & minimum 1 hr. labor will be charged for all booth materials (booth displays, flooring, etc.) that are left unclaimed after show move-out.

**Overtime/Double-time** Surcharge: Overtime: 30% Double Time: 50%

Shipments that are moved and/or handled on overtime and/or double time hours will incur a surcharge based on the handling times noted on the receiving/shipping documents. Drivers picking up outbound shipments will be sequenced for loading ONLY after a bill of lading is submitted to the Shepard Service Desk AND the driver has checked in.

**Warehouse Overtime/Double-time** Surcharge: Overtime: 30% Double Time: 50%

Advanced shipments may be received during straight time hours at the warehouse location, however an overtime/double time surcharge may be applied to an advanced warehouse shipment due to required delivery schedule based on show move-in and move out hours beyond our control. This would also be true if freight was received after hours at the warehouse trapping facility.

**Early/Late Shipments to the Warehouse** Surcharge: 25% 35003

A surcharge will apply to shipments not arriving within the published dates (refer to Show Information page for dates) for advance warehouse or arriving on show site after show opening. Any shipment arriving to show site after show open will be charged a surcharge.

**Uncrated Shipments** Rate as shown on Material Handling Rate Form

An additional charge of 50% (or as stated on Material Handling Authorization page) of the applicable material handling charge at the time of delivery shall be charged for all loose, uncrated, or unprotected shipments received at the show site docks. The charge is a one-time charge that includes both move-in and move-out of the show, and is based on the weight of the shipment handled.

**Off-Target Deliveries** Surcharge: 15% 35004

For targeted shows (exhibitors who received/requested a Targeted Date/Time), a surcharge will apply if shipment is not delivered (or carrier has not checked in) during assigned target date/time.

**Marshaling Yard** Fee: \$30 per Shipment 35250

Where Shepard Exposition Services as the show contractor must lease space for marshaling yard operations because no space is provided by the facility, Shepard may charge a one time fee per shipment processed inbound and/or outbound through the marshaling yard.

**Reweigh of Shipments** Fee: \$25.00 per forklift load 35282

An additional charge per forklift load will be applied to shipments that have to be reweighed at the dock due to the lack of a certified weight ticket, or an incorrect or understated weight on a delivery document.

**Empty Crate Storage** Fee: \$25.00 per piece. 35105

A charge per crate, carton or skid applies when Shepard handles the storage and return of empties from a shipment not received by Shepard and therefore not subject to material handling charges.

### Light Weight Shipments

Shipments weighing 40 lbs. or less will qualify for the light weight shipment rate. Shipments exceeding 40 lbs. will be billed standard Material Handling fees at the prevailing show rates. All shipments must have certified weight tickets.

**Envelope Deliveries** Fee: \$10.50 per envelope 35007

During show hours at the show facility, a charge will apply to receiving and delivering envelope packages to your booth.

**Mobile Spotting** Fee: \$ 200.00 per round trip 35106

All vehicles must be escorted in and out of building by Shepard personnel.

**Shepard Exposition Services is the sole provider of Material Handling Services. Exhibitors or their hired EAC/Carriers may not deliver freight to exhibit spaces or operate any type of mechanical or powered equipment. Material handling is a billable service.**

**What is material handling (also referred to as drayage)?**

Material handling is the process of unloading your freight from your shipping carrier, either at the warehouse or show site, delivering it to your booth, storing your empty containers (empties) if required, returning of your empties at the close of show, and then reloading your freight back onto your shipping carrier.

**What is the definition of "freight"?** Any exhibit materials shipped or delivered to the advance warehouse or show facility via shipping carrier, POV, or delivery truck.

**What is the difference between material handling and shipping?**

Shipping is the process of transporting your shipment from its origin to its final destination. Material handling begins at the time your shipment arrives to the docks (please refer to "What is material handling?" for the full definition.) These are 2 different items and are billed differently.

**Do I need to order a forklift to unload or reload my freight?** No, please do not order a forklift for unloading/reloading of your materials.

**What does CWT mean?** CWT is an acronym for Century Weight.

**What determines how much I'm charged?** Charges are based on certified inbound weight ticket included with your shipment as well as the type of service required

**How do I calculate material handling charges?**

Material handling, whether used completely or in part are offered as a round trip service. When recording weight, round up to the next 100 lbs. EXAMPLE: 285 lbs. = 300 lbs./100 lbs. = 3 X RATE = \$ Amount or minimum charge, whichever is greater.

**Will there be any additional charges?**

Additional charges may apply. Please review the Material Handling Authorization and Material Handling Additional Services forms included in the manual for all applicable fees

**What are Light Weight shipments?**

All shipments regardless of carrier that weigh 40 pounds or less. Shipments need to have certified weight tickets or other verifiable weight noted upon delivery. Shipments without certified weight tickets may be subject to special handling or reweigh fees. Packages that arrive separately at different times or days will be billed separately.

All shipments, regardless of carrier, weighing 41 lbs. and up will be billed using the standard material handling rates listed in the kit and billed at a 200 lb. minimum.

**How do I calculate my Light Weight shipment?** Charges for Light Weight shipments are total shipment weight, per delivery. Any shipment above 40 lbs. will not qualify for this rate. Please be advised that your whole shipment may not arrive to its destination at one time. Therefore you may be charged per each delivery.

**What are Crated materials?**

Materials delivered that are skidded or in a container that can easily be unloaded/reloaded with no additional handling required.

**What are Uncrated materials?**

Materials delivered that are loose, pad-wrapped or unskidded without proper lifting bars and/or hooks.

**What is Special Handling?**

Shipments received that are packed in a manner as to require additional handling/labor are deemed special handling. Examples of shipments falling into this category would be constricted space unloading, ground unloading, stacked shipments, designated piece unloading, shipment integrity, mixed shipments, no bill of lading or documentation, carpet/pad only shipments.

**What are Advance Shipments?**

All shipments that are addressed to the advance warehouse address (please refer to "Advance Warehouse" shipping labels included in this manual)

Shepard will begin accepting your shipments 30 days prior to first show open day (date may vary depending on show schedule)

The warehouse will receive shipments Monday-Friday, 8:00 AM - 4:00 PM, excluding holidays

Shipments must arrive by advance warehouse deadline date to avoid a late surcharge. (Please refer to the "Show Information" page included with this manual for deadline date.

Crates, cartons, skids, fiber cases, and carpets can be accepted at the warehouse, but DO NOT ship crates weighing over 5,000 lbs., loose/uncrated shipments and/or machinery to warehouse. You must ship those items direct to show site.

All shipments must have a bill of lading or delivery slip indicating number of pieces and weight. Certified weight tickets required

All shipments must be prepaid, no collect on delivery shipments will be accepted.

**What are Direct Shipments?**

All shipments that are addressed directly to the exhibit facility (please refer to "Direct to Show" shipping labels included in this manual).

Shipments must arrive during published exhibitor move-in times only. Do not ship direct to show site in advance. If delivery cannot be guaranteed to arrive during exhibitor move-in, shipment must go to advance warehouse.

All shipments must have a bill of lading or delivery slip indicating number of pieces and weight. Certified weight tickets required.

Crates weighing over 5,000 lbs. or loose/uncrated shipments must be shipped direct to show site to arrive during exhibitor move-in times.

All shipments must be prepaid, no collect on delivery shipments will be accepted.

**What is and why would I need liability insurance?**

Accidents happen, therefore, most show organizers and facilities require liability insurance. Please refer to your booth contract for exact minimums required.

Please make sure your materials are covered from the moment they leave your company location to the time they return after the close of the show

If applicable, included in your manual is information and an application for liability insurance and booth coverage can also be purchased to protect your valuable exhibit materials

**Outbound Shipping**

You must complete a Shepard Material Handling Agreement (MHA) for all outbound shipments. A MHA will be distributed at show site if all services have been paid in full, or you can request one at the customer service desk.

Upon completion of packing and labeling of your materials, complete the bill of lading (MHA) with all required information, and return to the customer service desk. If you have questions on how to complete your bill of lading (MHA), please ask a Shepard customer service representative located at the customer service desk.

If you are NOT using the designated show carrier, you must call your carrier with pick-up information. If your carrier fails to pick up your shipment, Shepard Logistics will either reroute your freight through the carrier of our choice or return to the local warehouse (whichever is indicated on your MHA).

**Equipment: Exhibitors or their EACs may not utilize or operate any type of material handling mechanical or powered equipment. If you need assistance, please contact us to order labor and equipment.**



**AFCEA Belvoir PEO Industry Days**

Gaylord National Resort & Convention Ctr (Prince George Exhibits) - National Harbor, MD

November 17 - 18, 2020

Event Code: M145781120  
email baltimore@shepardes.com  
phone (410) 737-9270  
fax (410) 737-9274

**Labor Hours**

ST - Straight time: Monday - Friday 8AM - 5PM.  
OT - Overtime: Monday - Friday 5PM - 8AM. All hours Saturday and Sunday.  
DT - Double-time: Holidays.  
Holidays NY Day, ML King Day, Presidents Day, Memorial Day, Independence Day, Labor Day, Veterans Day, Thanksgiving Day, Christmas Eve Day, Christmas Day.

Cartload services are provided to those exhibitors arriving in privately-owned vehicles and have small hand-carried items that need to be delivered to and from the dock/booth location. Exhibitors may not utilize mechanical or powered equipment to unload their items.

If you arrive with a truck, van, trailer, or truck with trailer filled with exhibit material you will not qualify for this service and will be redirected.

No personal trucks (one (1) ton & over), no rental trucks, trailers, or bobtails will be unloaded through cartload service.

All items must fit on flat bed cart (approximately 3'x4' in size) and weigh less than 200 pounds. If items are designated by Shepard personnel to be too large or too heavy, materials will be billed at regular material handling rates.

Your vehicle must unload on the receiving dock of the exhibit hall. Shepard personnel will direct vehicles. The cart is not authorized to enter or go to any parking structure. There must be two (2) people with the vehicle; one person to go with your product to the booth space and one person to remove your vehicle from the unloading area to the parking area.

**Cartload Service includes one laborer, one cart, one trip per rate listed below.**

Item	Code	# of Trips	Rate	Total
Dock to Booth ST	35151	_____	\$133.99	_____
Booth to Dock ST	35152	_____	\$133.99	_____
Dock to Booth OT	35153	_____	\$180.99	_____
Booth to Dock OT	35154	_____	\$180.99	_____



**Only Shepard personnel are allowed to operate mechanical equipment.**

Total Estimate: \$ \_\_\_\_\_  
6.000% Tax\*: \$ \_\_\_\_\_  
Amount Due: \$ \_\_\_\_\_

No refunds or exchanges once service has been rendered.

Cancellations must be received in writing within 48 hours of 1st day of exhibitor move in.

Company Name: \_\_\_\_\_ Booth # \_\_\_\_\_  
Contact Name \_\_\_\_\_  
Email: \_\_\_\_\_  
Signature: \_\_\_\_\_



AFCEA Belvoir PEO Industry Days

Gaylord National Resort & Convention Ctr (Prince George Exhibits) - National Harbor, MD

November 17 - 18, 2020

Event Code: M145781120
email: baltimore@shepardes.com
phone: (410) 737-9270
fax: (410) 737-9274

On Site Storage is used when you have product you need to replenish during the event, or if you have items you don't want stored with the empty crates. Do not use this service for "Empty" storage.

Step One: Tell us who you are:

Exhibiting Company Name: Booth #:
Name: #:

Onsite Contact: Onsite Cell Phone #:

For liability reasons, only shipments for which material handling drayage charges have been paid to Shepard will be eligible for Shepard storage services.

All packages must be properly packed & labeled. Shepard Exposition Services' limit of liability will be \$5.00 per pound or \$500.00 per package or container, whichever is less. No uncrated material will be accepted at the warehouse.

Step Two: Choose the Type of storage to fit your needs

For either storage options, there is no charge to return items back to your booth at the end of the event.

Accessible Storage Use this type when you need to pull items out of storage during the show. Materials in Accessible Storage will be accessible during the event, but not necessarily by exhibitors. The charge for Accessible Storage is a daily storage fee plus a per hour labor fee each time materials are moved. (\$100.00 Minimum) (35166)

Table with 4 columns: Item Code, Description, Type, Per Day Rate. Rows include Pallets/Skids (\$35.00), 1/2 a Trailer (\$80.00), Full Trailer (\$120.00), Labor ST (\$93.99), Labor OT (\$140.99), Labor DT (\$187.98).

Secured Storage Use this type only if you do not need your items again until the end of the event. Materials will be placed into secured storage and will be returned to your booth after the close of the show. The materials will be accessible during the show by Shepard personnel only. A minimum one-hour material handling labor charge at show rates will apply each time material is handled to or from storage. (\$100.00 Minimum). (35068)

Table with 4 columns: Description, Per Sq Ft, # of Days, Total. Rows include Labor ST (\$93.99, 35087), Labor OT (\$140.99, 35100), Labor DT (\$187.98, 35101).

Submission of this form indicates you read and accept the Payment Policy and Terms & Conditions. No refunds or exchanges once item has been delivered to your booth. Cancellations must be received in writing within 48 hours of 1st day of exhibitor move in. Only Shepard personnel are allowed to operate mechanical equipment.

Total Onsite Storage: \$
6.000% Tax\*: \$
Amount Due: \$

Company Name: Booth #
Contact Name
Email:
Signature:



AFCEA Belvoir PEO Industry Days

Gaylord National Resort & Convention Ctr (Prince George Exhibits) - National Harbor, MD

November 17 - 18, 2020

Event Code: M145781120
email: baltimore@shepardes.com
phone: (410) 737-9270
fax: (410) 737-9274

Warehouse Storage is used when you need a place to store your exhibit or product for days, weeks, or even until your next event.

Pricing:

Warehouse storage rates are billed \$10.00 per cwt per month (\$100.00 a month minimum charge) 35006
Each shipment returned to the warehouse for storage will be billed \$20.00 per cwt (\$400.00 minimum) 35005
Onsite Material Handling fees do not include transportation or handling to and from the warehouse.

For liability reasons, only shipments for which material handling drayage charges have been paid to Shepard will be eligible for Shepard storage services.

All packages must be properly packed & labeled. Shepard Exposition Services' limit of liability will be \$5.00 per pound or \$500.00 per package or container, whichever is less. No uncrated material will be accepted at the warehouse.

Step One: Tell Us Who You Are:

Exhibiting Company Name \_\_\_\_\_ Booth # \_\_\_\_\_
Onsite Contact \_\_\_\_\_ Onsite Cell Phone # \_\_\_\_\_
Email Address \_\_\_\_\_

Step Two: Tell Us What You Are Storing:

How many pieces? \_\_\_\_\_

What are the dimensions of each piece?

Table with 6 columns: Length, Width, Height, Weight, Crate or Skid? and 6 rows: Piece 1 to Piece 6.

Table with 6 columns: Length, Width, Height, Weight, Crate or Skid? and 6 rows: Piece 7 to Piece 12.

Step Three: How Long Are We Storing Your Items?

From Date \_\_\_\_\_ To \_\_\_\_\_ Fees will continue until storage is picked up.

Step Four: What Do We Do With Your Items At The End Of The Storage Period?

Ship to another destination via Shepard Logistics\*
Pick-up is arranged with another carrier:
Transport to another Shepard event\*:
\*Additional fees will apply

It is the exhibitor's responsibility to make all arrangements for shipping, including utilizing Shepard Logistics. Items will not automatically be taken to the next event. Exhibitor should contact Shepard approximately 2 weeks prior to any storage movement.

Submission of this form indicates you read and accept the Payment Policy and Terms & Conditions.
Storage Items will not be stored or released without a valid credit card on file.
Estimated Warehouse Storage: \$
6.000% Tax\*: \$
Amount Due: \$

Printed Name: \_\_\_\_\_

Signature: \_\_\_\_\_



**AFCEA Belvoir PEO Industry Days**

Gaylord National Resort & Convention Ctr (Prince George Exhibits) - National Harbor, MD

November 17 - 18, 2020

**Discount Deadline Tuesday, October 27, 2020**

Order with complete Payment Authorization and graphics must be received before Discount Deadline date to receive discounted pricing.

Event Code: M145781120  
email baltimore@shepardes.com  
phone (410) 737-9270  
fax (410) 737-9274

**Abandoned Carpet / Floor coverings and Display Materials**

Exhibitors are required to remove all floor coverings and display materials from their exhibit space prior to leaving the facility during move out.

Exhibitors who abandon floor coverings and/or displays, leave large or heavy amounts of trash will be charged labor plus disposal fees for Shepard to remove the materials. The rates for this service are shown below. **If you need to dispose of your exhibit, carpet, padding, or other large/heavy materials, please pre-arrange the removal with us!**

**Labor and Forklifts will be billed per man hour. Dumpster fees will be billed per amount of space used. All related disposal fees will be added to the payment method on file.**

**Labor**

Code	Item	Qty	Discount	Regular
68066	ST Labor	_____	\$156.98	\$204.05
68067	OT Labor	_____	\$235.46	\$306.10
68068	DT Labor	_____	\$313.95	\$408.15

**Forklift**

Code	Item	Qty	Discount	Regular
35028	ST 5k Forklift	_____	\$321.75	\$418.25
35039	OT 5k Forklift	_____	\$398.10	\$517.50
35067	DT 5k Forklift	_____	\$474.45	\$616.75

**Dumpster Fee**

Code	Item	Qty	Discount	Regular
35330	Per Full Dumpster	_____	\$650.00	\$845.00

Submission of this form indicates you read and accept the Payment Policy and Terms & Conditions.

There are no exchanges or refunds once item has been delivered to your booth. Cancellations must be received in writing within 14 days prior to first exhibitor move in day.

Rental items found and in use in your booth are subject to "Standard" pricing.

Total Disposal Fee: \$ \_\_\_\_\_  
6.000% Tax\*: \$ \_\_\_\_\_  
Amount Due: \$ \_\_\_\_\_

Company Name: \_\_\_\_\_ Booth # \_\_\_\_\_

Contact Name \_\_\_\_\_

Email: \_\_\_\_\_

Signature: \_\_\_\_\_

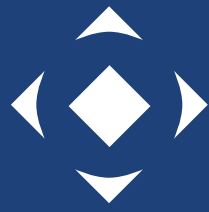

# Shepard

# FURNISHINGS AND DECOR



Exhibit  
Rental



Traffic  
Builders



Logistics &  
Transportation



Furniture  
Rentals



Material Handling  
& Ground Rigging



More!

# Tables

## UNSKIRTED



**Display Table**  
#50040  
4' x 24" x 30"  
Unskirted



**Display Table**  
#50041  
4' x 24" x 42"  
Unskirted



**Display Table**  
#50044  
6' x 24" x 30"  
Unskirted



**Display Table**  
#50045  
6' x 24" x 42"  
Unskirted



**Display Table**  
#50048  
8' x 24" x 30"  
Unskirted



**Display Table**  
#50049  
8' x 24" x 42"  
Unskirted

## SKIRTED - 6' & 8' Long Tables are Skirted on 3 Sides. For Skirting on 4 Sides, Please Order 4th Side Skirt.



**Display Table**  
#50042  
4' x 24" x 30"  
Skirted



**Display Table**  
#50043  
4' x 24" x 42"  
Skirted



**Display Table**  
#50046  
6' x 24" x 30"  
Skirted



**Display Table**  
#50047  
6' x 24" x 42"  
Skirted



**Display Table**  
#50050  
8' x 24" x 30"  
Skirted



**Display Table**  
#50051  
8' x 24" x 42"  
Skirted

## PEDESTAL & SIDE



**30" Natural Pedestal Table**  
#50706  
30" x 36"  
Natural Feel Pedestal Table, Maple Top, Black Base



**42" Natural Pedestal Table**  
#50707  
42" x 36"  
Natural Feel Pedestal Table, Maple Top, Black Base



**30" Pedestal Table**  
#50032  
30" x 36"  
Pedestal Table, Grey Fleck Top, Chrome Base



**42" Pedestal Table**  
#51089  
42" x 36"  
Round High Pedestal Table, Grey Fleck Top, Chrome Base



**Round Side Table**  
#50030  
18" x 24"



**Square Side Table**  
#50031  
18" x 18" x 24"



# Chairs

## STOOLS



**Director's Stool**  
#51090  
Black Fabric, Maple Wood



**Natural Feel Stool**  
#50705  
Light Maple Back, Black Fabric Seat



**Padded Stool**  
#50024  
Padded Stool with Back, Grey Fabric

## CHAIRS WITH ARMS



**Director's Stool**  
#51086  
Black Fabric, Maple Wood



**Upholstered Arm Chair**  
#50021  
Upholstered Arm Chair, Grey Fabric

## CHAIRS WITHOUT ARMS



**Natural Feel Chair**  
#50704  
Light Maple Back, Black Fabric Seat



**Upholstered Side Chair**  
#50020  
Upholstered Side Chair, Grey Fabric

# Display

## FOR HANGING



**Bag Rack**  
#50175  
9" x 12" x 71"  
Adjustable Heights



**Coat Rack**  
#50092  
2" x 22" x 69"  
Silver



**Spiral Garment Rack**  
#50093  
30" x 70"  
Silver



**2' x 8' Grid with Legs**  
#50236  
2' x 8'  
Chrome

Also Available Without Legs (#50237)



**3.5' x 8' Slatwall**  
#50249  
3.5' x 8'  
Grey



**4' x 8' Peg Board**  
#50594  
4' x 8'  
White



**6" Hooks for Peg Board**  
#50104  
Silver

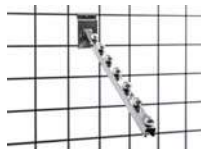

**7-Ball Waterfall Grid Attachment**  
#50242  
Silver  
Also Available for Slat Wall #50243

# Display

## UPRIGHT, CROSSBAR, & DRAPERY



**8' High Upright with Base**  
#50088  
Crossbar rented separately



**6' - 10' Crossbar**  
#50349  
1 1/4" D



**7' - 12' Crossbar**  
#50348  
1 1/4" D



**3' High Drape**  
#50074



**8' High Drape**  
#50074

## FOR SIGNS & LITERATURE



**Horizontal Tackboard**  
#50060  
4' x 8'  
Black Legs, Grey Fabric



**Vertical Tackboard**  
#50061  
8' x 4'  
Black Legs, Grey Fabric



**Literature Rack**  
#50245  
16" x 10" x 59"



**Chrome Sign Holder**  
#50095  
Holds 22" x 28" Sign



**Floor Easel**  
#50094  
31" x 31" x 64"

## SHELVING



**4' x 12" Display Shelf**  
#50296  
4' x 12"  
White Shelf with Black Bases



**6' x 12" Display Shelf**  
#50297  
6' x 12"  
White Shelf with Black Bases

## BARRIER



**Tensa Barrier Stanchion**  
#50427  
Barrier with Black Belt  
Barrier 13" x 41"  
Black Belt 117"  
Rented individually, not a set

## OTHER



**Natural Feel Wastebasket**  
#50708  
Beige Wastebasket



**Wastebasket**  
#50091



**Mini Refrigerator**  
#50098



**Drawing Bowl**  
#51085



**Sand Bag**  
#51087

\*The product photos shown are representative of the products. Actual products and colors may vary from the images shown. Not every item or every color will be available on every event.

# Showcase



**4' Full View Showcase**  
#50067

**6' Full View Showcase**  
#50068



**4' Quarterview Showcase**  
#50069

**6' Quarterview Showcase**  
#50070

# Flooring

## EXPO - 13oz



## PREMIUM - 28oz



## PLUSH - 50oz

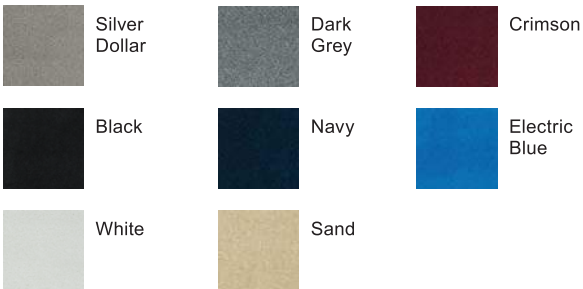

## VINYL - Custom Order Only



# Skirt Color Options

## SKIRT



Gold



Blue



Red



Green



Teal



Burgundy



Black



Grey



White

## SPANDEX



Blue



Red



Black



White

# Drape Color Options



Gold



Blue



Red



Green



Teal



Burgundy



Black



Grey



White



**AFCEA Belvoir PEO Industry Days**

Gaylord National Resort & Convention Ctr (Prince George Exhibits) - National Harbor, MD

November 17 - 18, 2020

**Discount Deadline Tuesday, October 27, 2020**

Order with complete Payment Authorization must be received before Discount Deadline date to receive discounted pricing.

Event Code: M145781120  
 email: [baltimore@shepardes.com](mailto:baltimore@shepardes.com)  
 phone: (410) 737-9270  
 fax: (410) 737-9274

**Tables**

Code	Item	Qty	Color	Discount	Regular	Total
50042	4'L X 30"H X 24"W Skirted Table			\$162.30	\$211.00	
50046	6'L X 30"H 24"W Skirted Table			\$199.50	\$259.35	
50050	8'L X 30"H 24"W Skirted Table			\$252.90	\$328.75	
50043	4'L X 42"H 24"W Skirted Table			\$197.30	\$256.50	
50047	6'L x 42"H 24"W Skirted Table			\$252.65	\$328.45	
50051	8'L x 42"H 24"W Skirted Table			\$297.20	\$386.35	
50052	4th Side Skirt for 30" High Table			\$98.65	\$128.25	
50171	4th Side 42" Skirt for 42" High Table			\$98.65	\$128.25	
50700	6'L X 30"H 24"W Spandex Table Cover			\$295.90	\$384.65	
50040	4'L X 30"H X 24"W UnSkirted Table		na	\$115.65	\$150.35	
50044	6'L X 30"H X 24"W UnSkirted Table		na	\$138.00	\$179.40	
50048	8'L X 30"H X 24"W UnSkirted Table		na	\$162.70	\$211.50	
50041	4'L X 42"H X 24"W UnSkirted Table		na	\$130.25	\$169.35	
50045	6'L x 42"H X 24"W UnSkirted Table		na	\$162.70	\$211.50	
50049	8'L x 42"H X 24"W UnSkirted Table		na	\$181.55	\$236.00	
51089	Pedestal Table,42"H 36"R Grey Fleck Top		na	\$291.45	\$378.90	
50032	Pedestal. Table,30"H 36"R Grey Fleck Top		na	\$272.50	\$354.25	
50030	Round Side Table 24" W X 18" H		na	\$137.15	\$178.30	
50031	Square Side Table 24" W X 18" H		na	\$137.15	\$178.30	
50706	Natural Pedestal Table 30"H X 36" R Maple Top		na	\$356.55	\$463.50	
50707	Natural Pedestal Table 42"H X 36"R Maple Top		na	\$371.65	\$483.15	

Skirt Colors (6' and 8' Skirted Tables have skirts on 3 sides, to have drape on all 4 sides you must order 4th side drape)

Red (01) Green (02) White (03) Gold (04) Blue (05) Black (06) Burgundy (07) Grey (10) Teal (13) Spandex Red (01) White (03) Blue (05) Black (06)

**Seating**

Code	Item	Qty	Color	Discount	Regular	Total
50020	Side Chair Grey Fabric		na	\$105.50	\$137.15	
50021	Arm Chair Grey Fabric		na	\$143.80	\$186.95	
50024	Stool w/back Grey Fabric		na	\$175.20	\$227.75	
51086	Director's Chair Black Fabric		na	\$108.80	\$141.45	
51090	Director's Stool Black Fabric		na	\$194.75	\$253.20	
50705	Natural Feel Stool Maple Back, Black Fabric Seat		na	\$212.40	\$276.10	
50704	Natural Feel Chair, Maple Back, Black Fabric Seat		na	\$174.45	\$226.80	

Submission of this form indicates you read and accept the Payment Policy and Terms & Conditions.

There are no exchanges or refunds once item has been delivered to your booth. Cancellations must be received in writing within 14 days prior to first exhibitor move in day.

Rental items found and in use in your booth are subject to "Regular" pricing.

Total Furnishings: \$ \_\_\_\_\_  
 6.000% Tax\*: \$ \_\_\_\_\_  
 Amount Due: \$ \_\_\_\_\_

Company Name: \_\_\_\_\_ Booth # \_\_\_\_\_

Contact Name: \_\_\_\_\_

Email: \_\_\_\_\_

Signature: \_\_\_\_\_



**AFCEA Belvoir PEO Industry Days**

Gaylord National Resort & Convention Ctr (Prince George Exhibits) - National Harbor, MD

November 17 - 18, 2020

**Discount Deadline Tuesday, October 27, 2020**

Order with complete Payment Authorization must be received before Discount Deadline date to receive discounted pricing.

Event Code: M145781120  
 email: [baltimore@shepardes.com](mailto:baltimore@shepardes.com)  
 phone: (410) 737-9270  
 fax: (410) 737-9274

**Specialty & Display**

Code	Item	Qty	Color	Discount	Regular	Total
50091	Wastebasket		na	\$19.00	\$19.00	
50094	Floor Easel, Chrome		na	\$58.35	\$75.85	
50245	Literature Rack Silver, Glass		na	\$215.40	\$280.00	
50175	Bag Rack, Chrome		na	\$285.30	\$370.90	
50092	Coat Rack, Chrome		na	\$101.25	\$131.65	
50093	Garment Rack, Chrome		na	\$285.30	\$370.90	
50427	Tensabarrier, Per Stem, Black		na	\$120.30	\$156.40	
50095	Sign Holder, 22x28 Chrome		na	\$132.95	\$172.85	
50185	Drawing Bowl, Clear		na	\$53.55	\$69.60	
50296	4' x 12" Display Riser White and Black		na	\$120.50	\$156.65	
50297	6' x 12" Display Riser White and Black		na	\$149.95	\$194.95	
50098	Mini Refrigerator, Approx 3 cubic feet		na	\$455.00	\$591.50	
50067	4' Full View Showcase, White		na	\$1,075.10	\$1,397.65	
50068	6' Full View Showcase, White		na	\$1,185.75	\$1,541.50	
50069	4' Quarter View Showcase, White		na	\$1,075.10	\$1,397.65	
50070	6' Quarter View Showcase, White		na	\$1,185.75	\$1,541.50	
50060	4' x 8' Horz. Posterboard Grey Fabric		na	\$348.15	\$452.60	
50061	4' x 8' Vert. Posterboard Grey Fabric		na	\$348.15	\$452.60	
50236	Grids 2'x8' w/legs, each		na	\$257.15	\$334.30	
50237	Grid 2'x8' w/o legs, each		na	\$192.60	\$250.40	
50242	7-Ball Waterfall for Grids		na	\$17.70	\$23.00	
50104	6" Hooks (12) for Peg Boards		na	\$56.60	\$73.60	

**Drapery**-per linear foot, min 5' linear feet rental

Code	Item	Qty	Color	Discount	Regular	Total
50073	8' High drape on a cross bar, per linear foot			\$27.30	\$35.50	
50074	3' High on a cross bar, per linear foot			\$20.20	\$26.25	
50088	8' Upright w/base		na	\$37.70	\$49.00	
52065	3' Upright w/base		na	\$37.70	\$49.00	
50349	6'-10' Crossbar		na	\$25.10	\$32.65	
50348	7'-12' Crossbar		na	\$25.10	\$32.65	
50058	Sateen, per linear foot			\$22.30	\$29.00	

Drape and Sateen Colors Red (01) White (03) (04) Blue (05) Black (06) Burgundy (07) Grey (10)

Submission of this form indicates you read and accept the Payment Policy and Terms & Conditions.

There are no exchanges or refunds once item has been delivered to your booth. Cancellations must be received in writing within 14 days prior to first exhibitor move in day.

Rental items found and in use in your booth are subject to "Regular" pricing.

Total Furnishings: \$ \_\_\_\_\_  
 6.000% Tax\*: \$ \_\_\_\_\_  
 Amount Due: \$ \_\_\_\_\_

Company Name: \_\_\_\_\_ Booth # \_\_\_\_\_

Contact Name: \_\_\_\_\_

Email: \_\_\_\_\_

Signature: \_\_\_\_\_

## AFCEA Belvoir PEO Industry Days

Gaylord National Resort & Convention Ctr (Prince George Exhibits) - National Harbor, MD

November 17 - 18, 2020

**Discount Deadline Monday, October 19, 2020**

Order with complete Payment Authorization must be received before Discount Deadline date to receive discounted pricing.

Event Code: M145781120  
 email: [baltimore@shepardes.com](mailto:baltimore@shepardes.com)  
 phone: (410) 737-9270  
 fax: (410) 737-9274

**Order must be received 30 days in advance of show move in. 100 sq ft minimum**

**Step One:** Choose the flooring to enhance your design

**Step Two:** Check the box of your selected color

**Step Three:** Determine your booth size (length x width = square footage)

### Premium Plush Carpet 50 oz

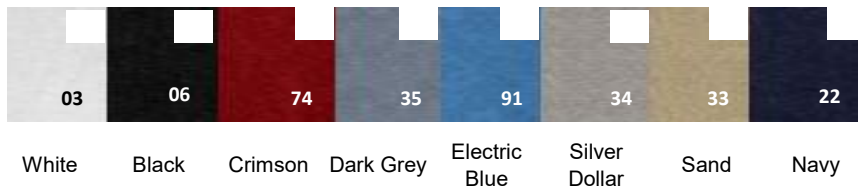

Code	Sq Ft	Item	Per Sq Ft	Amount
46004		Premium Plush	\$11.50	

Rental includes installation and removal of carpet and visqueen. Minimum 100 sq. ft. required.

### Premium Vinyl Flooring



Code	Sq Ft	Item	Per Sq Ft	Amount
46005		Premium Vinyl	\$14.90	

Code	Sq Ft	Item	Per Sq Ft
50712		Light Oak	Call for Quote!
50711		Dark Oak	Call for Quote!

Labor not included in hardwood flooring. Please order labor for the installation of your elevated floor.

Code	Sq Ft	Item	Per Sq Ft	Amount
46007		1/2" Padding for Vinyl	\$5.45	

### Elevated Hardwood



Stand above the rest with an Elevated Hardwood Floor! Contact an ESS Representative for pricing!

Submission of this form indicates you read and accept the Payment Policy and Terms & Conditions. Due to the custom nature of this product, **no refunds or exchanges once item has been ordered.**

Total Signature Flooring: \$ \_\_\_\_\_  
 6.000% Tax\*: \$ \_\_\_\_\_  
 Amount Due: \$ \_\_\_\_\_

Company Name: \_\_\_\_\_ Booth # \_\_\_\_\_  
 Contact Name: \_\_\_\_\_  
 Email: \_\_\_\_\_  
 Signature: \_\_\_\_\_



**AFCEA Belvoir PEO Industry Days**

Gaylord National Resort & Convention Ctr (Prince George Exhibits) - National Harbor, MD

November 17 - 18, 2020

**Discount Deadline Tuesday, October 27, 2020**

Order with complete Payment Authorization must be received before Discount Deadline date to receive discounted pricing.

Event Code: M145781120  
 email: [baltimore@shepardes.com](mailto:baltimore@shepardes.com)  
 phone: (410) 737-9270  
 fax: (410) 737-9274

**Step One:** Choose the carpet to fit your budget

**Step Two:** Check the box of your selected color

**Step Three:** Determine your booth size (length x width = square footage)

**Premium Carpet 28 oz, 100% Ultra cut pile with action back or jute backing**



Code	Qty	Item	Discount	Regular	Amount
46001		Rental/sqft	\$8.30	\$10.80	
46003		Rental 1000+ sqft	\$7.20	\$9.35	
46002		Purchase sqft	\$20.40	\$26.50	

Rental includes installation and removal of carpet and visqueen. Minimum 100 sq. ft. required.  
 Minimum 100 sq. ft. is required for purchase carpet. No refunds on cancellations.

**Padding & Visqueen** Entice attendees to linger in your space with soft, comfortable padding!

Code	Qty	Item	Discount	Regular	Amount
50009		1/2" Padding	\$1.50	\$1.95	
50008		1" Padding	\$2.95	\$3.85	
50010		Visqueen	\$0.45	\$0.60	

Rental includes installation and removal of padding/visqueen. Minimum 100 sq. ft. required.

**Expo Carpet 13 oz. 2 Options: Regular and Special Cut!**



**Standard Booth Sizes**, Great for inline booths!

**Special Cut**, Recommended for Island and large area exhibits!

Code	Qty	Item	Discount	Regular	Amount
50255		10' x 10'	\$291.15	\$378.50	
50256		10' x 20'	\$543.25	\$706.25	
50257		10' x 30'	\$810.30	\$1,053.40	
50258		10' x 40'	\$1,077.30	\$1,400.50	

Code	Qty	Item	Discount	Regular	Amount
50580		0 - 399 sq ft*	\$6.85	\$8.90	
50581		400 - 900 sq ft	\$6.15	\$8.00	
50582		900+ sq ft	\$5.70	\$7.40	

Variation in dye lot may occur when ordering more than one cut of carpet unless ordered as Special Cut Carpet.

Order Special Cut when it is important that dye lots match. Rental includes installation and removal of carpet and visqueen protective covering. 100 sq ft minimum order.

Prices quoted above include installation and taping of front edge only. All rental carpet is delivered clean to your booth space, but during setup, carpet may become dirty. **Please order cleaning service at least once before show opening.**

Submission of this form indicates you read and accept the Payment Policy and Terms & Conditions. **Total Carpet and Padding: \$ \_\_\_\_\_**  
 There are no exchanges or refunds once item has been delivered to your booth. Cancellations must be received in writing within 14 days prior to first exhibitor move in day. No refunds on "Special Cut" carpet once order is placed. **6.000% Tax\*: \$ \_\_\_\_\_**  
**Amount Due: \$ \_\_\_\_\_**

Rental items found and in use in your booth are subject to "Regular" pricing.

Company Name: \_\_\_\_\_ Booth # \_\_\_\_\_  
 Contact Name \_\_\_\_\_  
 Email: \_\_\_\_\_  
 Signature: \_\_\_\_\_



## AFCEA Belvoir PEO Industry Days

Gaylord National Resort & Convention Ctr (Prince George Exhibits) - National Harbor, MD

November 17 - 18, 2020

**Discount Deadline Tuesday, October 27, 2020**

Order with complete Payment Authorization and graphics must be received before Discount Deadline date to receive discounted pricing.

Event Code: M145781120  
 email: [baltimore@shepardes.com](mailto:baltimore@shepardes.com)  
 phone: (410) 737-9270  
 fax: (410) 737-9274

As the General Service Contractor, Shepard has the exclusive cleaning contract for this show. Other service contractors will not be permitted to provide this service on the show floor.

**Minimum 100 square foot order for all cleaning services.**

If you have any issues at all regarding cleaning during the show, please contact the Service Desk immediately so we can make it right. Please do not wait until the end of the event.

Booth carpet is the first product installed on an exhibit floor. While carpet is installed clean, it will get dirty during the move in process due to debris in the air, aisles and other exhibitors. It is always recommended to order a one time vacuuming prior to the show opening.

### Booth Vacuuming



#### Vacuum Once

Code	Service	Sq Ft	Discount	Regular	Total
47050	0-399 sq. ft		\$0.52	\$0.70	
47051	400-900 sq.ft.		\$0.45	\$0.60	
47052	900+ sq. ft		\$0.45	\$0.60	

#### Daily Vacuum

Code	Service	Sq Ft	Discount	Regular	Total
47055	0-399 sq. ft		\$1.04	\$1.35	
47056	400-900 sq.ft.		\$0.95	\$1.25	
47057	900+ sq. ft		\$0.85	\$1.10	

### Porter Service (includes emptying wastebaskets within the booth every two hours during the show)



Code	Service	Sq Ft	Discount	Regular	Total
47030	One Time Porter		\$0.50	\$0.65	
47031	Daily Porter		\$1.05	\$1.35	

### Specialty Services



#### Mopping and Carpet Shampooing

Code	Service	Sq Ft	Discount	Regular	Total
47042	Mop One Time		\$0.65	\$0.85	
47022	Mop Daily		\$1.15	\$1.50	
47013	Sham/One Time		\$0.65	\$0.85	



#### Display Wipe Down (charged per hour)

Code	Service	Hours	ST	OT	Total
47043	One Time		\$156.98	\$235.46	
47044	Daily		\$156.98	\$235.46	

Vacuuming, Porter Service, Mopping, and Shampooing are based on total booth sq ft regardless of area being cleaned. Minimum order of 100 sq ft.

Submission of this form indicates you read and accept the Payment Policy and Terms & Conditions.

No refunds once the service has been performed in your booth.

Cancellations must be received in writing within 48 hours of 1st day of exhibitor move in.

Total Cleaning: \$ \_\_\_\_\_

6.000% Tax\*: \$ \_\_\_\_\_

Amount Due: \$ \_\_\_\_\_

Company Name: \_\_\_\_\_ Booth # \_\_\_\_\_

Contact Name \_\_\_\_\_

Email: \_\_\_\_\_

Signature: \_\_\_\_\_

# TRADESHOW <sup>2020</sup>

*Furnishings*



## FEATURING

- Powered Collections
- Modular Seating
- Executive Seating
- Communal Tables
- Bars & Barstools



# *Inspired Designs* for Maximum Engagement

Design an interactive booth that achieves your company vision and encourages attendees to connect, learn, and engage.



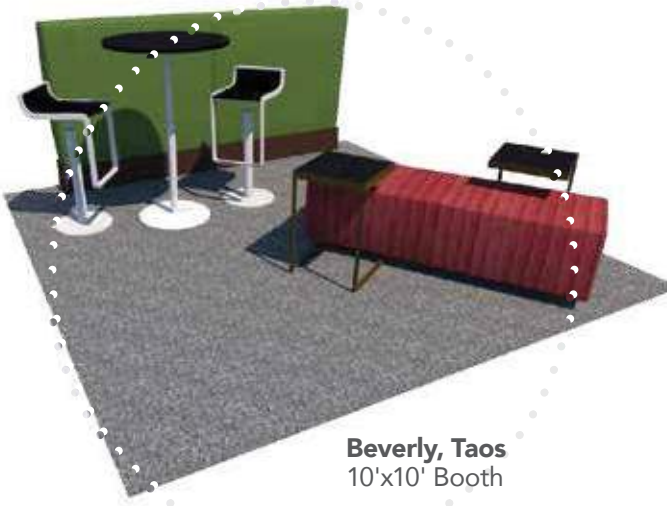

**Beverly, Taos**  
10'x10' Booth



**Malba, Beverly**  
10'x10' Booth



**Vibe, Christopher**  
10'x20' Booth



**Blade, Marche**  
10'x10' Booth

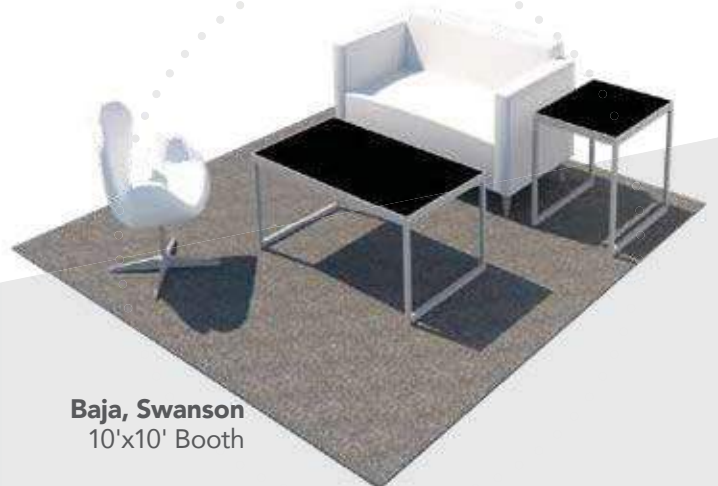

**Baja, Swanson**  
10'x10' Booth

# Top 10 Booth Design Tips

Attract, Engage and Inspire.

10.

**Provide a Pop!**  
Colorful furnishings attract attention and help reinforce brand themes.



1.

**Spin Around.**  
Swivel chairs in small spaces maximize functionality and allow you to engage with those all around!



2.

**Get Connected.**  
Communal tables help facilitate networking opportunities and build connections.



9.

**Charge it!**  
Powered tables or seating encourages clients to linger in the booth and recharge.



3.

**Creature Comforts.**  
Design a comfortable "living room" space with soft lounge seating to relax clients and encourage conversation.



8.

**Gather Round!**  
Ottomans styled around a side table create an informal camp fire setting for small group discussions.



4.

**Keep it Green.**  
Don't forget the greenery to warm up your booth environment by bringing nature indoors.



7.

**Stay Social.**  
Stylize furnishings to create shareable moments worthy of Instagram.



6.

**Level the field!**  
Low and casual seating makes clients more comfortable and open to learning.



5.

**Demo Down.**  
Square or circular ottomans are a great way to design small theaters for quick demonstrations.



**Roma Powered Seating and Rustique Table Booth**  
10'x20'

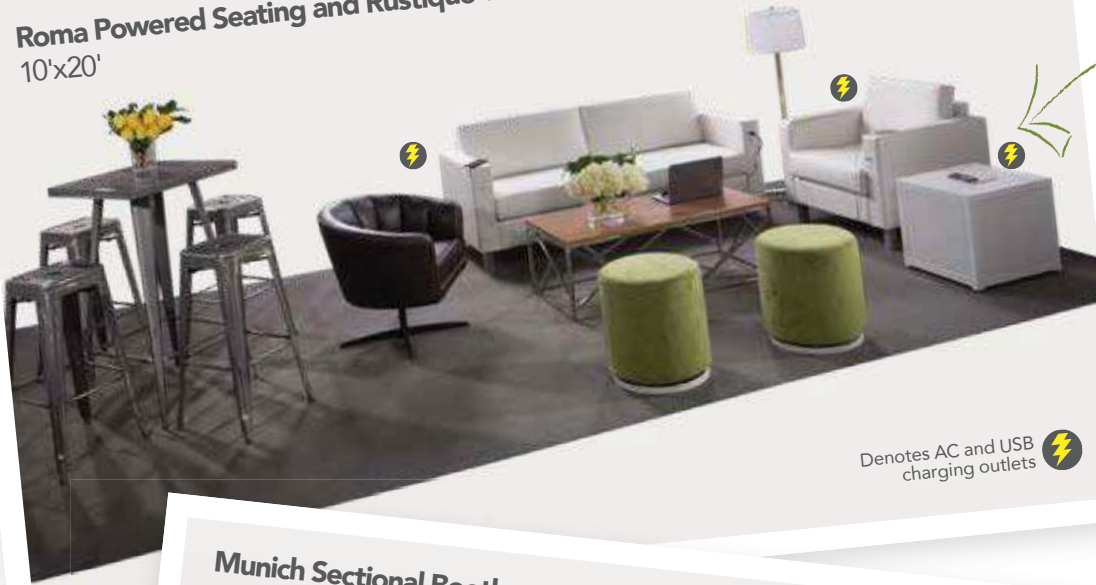

Denotes AC and USB charging outlets ⚡

Keep clients charged with powered seating and add a wireless charging table for attendees without charging cords.

**Munich Sectional Booth**  
10'x10'



Create a comfortable "living room" space with soft lounge seating to relax clients and facilitate conversation.

**Malba Conference and Beverly Demonstration Booth**  
10'x20'



Design multi-functional booths with areas for demonstrations and a place for conferencing.

# Powered Seating

Make searching for wall outlets a thing of the past and empower attendees at your next show with functional charging furniture from CORT Events. From pedestals to soft seating and tables, our complete charging collection lets you **Power Up the Possibilities.**

*Charge it!*

Powered tables or seating encourages clients to linger in the booth and recharge!



**CUBPOW**  
Wireless Charging Table, Powered  
(white, AC plug-in) 20"L 20"D 18"H

**Roma Powered Chair & Sofa**  
10'x20'

## Roma Collection

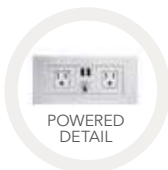

**SFAPWR Roma Sofa, Powered**  
(white vinyl) 78"L 31"D 33"H  
**CHRPWR Roma Chair, Powered**  
(white vinyl) 37"L 31"D 33"H

# Naples Collection

**NPLCHP Naples Chair, Powered** (black vinyl) 36"L 30"D 33.25"H  
**NPLLOP Naples Loveseat, Powered** (black vinyl) 62"L 30"D 33.25"H  
**NPLSOP Naples Sofa, Powered** (black vinyl) 87"L 30"D 33.25"H



# Banquettes

**BNQ417 Full Banquette**  
w/ Electrical Charging Outlet  
(white vinyl) 72"RND 51"H



**MODULAR SYSTEM** Create round banquettes or custom serpentine seating. The Power Banquette system has three AC and two USB plugs built into the center cone so your client will never be left powerless. Center power cone may also be rented as a free standing charging station (BNQTL7).

**Please Note:** Client is responsible for providing labor and an electrical power source to the furniture. One 110V power source is required for each charging panel. Two charging units can be daisy chained together. 10A max per charging panel.



# Powered Tables



A.



B.



C.



D.

*Get Connected.*  
Use communal tables  
in your design to facilitate  
networking.

E.



(Mobile devices must have Qi wireless charging capability.)



F.



G.

**Ventura Bar Tables, Powered** (silver frame) 72.25"L 26.25"D 42"H  
A) VNTWHT (white top) B) VNTBLK (black top)

**Ventura Cafe Tables, Powered** (silver frame) 72.25"L 26.25"D 30"H  
C) VNTCBK (black top) D) VNTCWH (white top)

**E) CUBPOW Wireless Charging Table, Powered** (white, AC plug-in) 20"L 20"D 18"H

**Sydney Powered Cocktail Tables** (brushed steel) 48"L 26"D 18"H  
F) C1WP (white top) G) C1YP (black top)



# Powered Pedestals

A. | B.



POWERED  
DETAIL



POWERED  
DETAIL



C. | D.



The flip-top electrical units rotate 180° to let devices charge on or inside the cabinet.

## Powered Locking Pedestals

- A) PDL36W** (white)  
24"L 24"D 36"H
- B) PDL42W** (white)  
24"L 24"D 42"H
- C) PDL36B** (black)  
24"L 24"D 36"H
- D) PDL42B** (black)  
24"L 24"D 42"H

# Powered Desk

B.



POWERED  
DETAIL



A.



## A) TECH3B Tech Desk, Powered w/3 drawer File Cabinet

(black metal, laminate)  
60"L 30"D 30"H

## B) TECH Tech Desk, Powered

(black metal, laminate)  
60"L 30"D 30"H

# Soft Seating Collections



*Valencia*

**VALSOF Sofa** (coffee brown velvet) 63"L 30.5"D 31"H  
**VALCHA Chair** (spice orange velvet) 28"L 30.5"D 31"H



*Fairfax*

**FAIRSW Sofa** (white vinyl, brushed metal) 62"L 26"D 30"H  
**FAIRCW Chair** (white vinyl, brushed metal) 27"L 26"D 30"H



*Allegro* CHR002 Chair (blue fabric) 36"L 34.5"D 30"H  
SFA002 Sofa (blue fabric) 73"L 34.5"D 30"H



*Roma*  SFAPWR Sofa, Powered (white vinyl) 78"L 31"D 33"H  
CHRPWR Chair, Powered (white vinyl) 37"L 31"D 33"H

*Palm Beach*  
PALSOF Sofa (white vinyl) 69"L 29"D 33"H



# Soft Seating



**MNCHSC**  
Munich Sectional 3pc.  
(gray fabric)  
93.5"L 27"D 28.5"H

**CUBPOW** ⚡  
Wireless Charging Table, Powered  
(white, AC plug-in) 20"L 20"D 18"H



Munich Booth 10'x20'

## Munich



**MNCHLV** Armless Loveseat  
(gray fabric) 45"L 27"D 28.5"H



**MNCHCC** Corner Chair  
(gray fabric) 26"L 27"D 28.5"H



**MNCHCH** Armless Chair  
(gray fabric) 22.5"L 27"D 28.5"H

# *Creature Comforts.*

Create a comfortable "living room" space with soft lounge seating to relax clients and facilitate conversation.



**Baja Booth 10'x20'**

## *Baja*



**BCHWHT Chair**  
(white vinyl) 36"L 30.5"D 28"H



**BLVWHT Loveseat**  
(white vinyl) 61"L 30.5"D 28"H



**BSFWHT Sofa**  
(white vinyl) 86"L 30"D 28"H

# Soft Seating Collections



## *Tangiers*

**TANCHR Chair** (beige textured) 34"L 37"D 36"H  
**TANLOV Loveseat** (beige textured) 57.5"L 37"D 37"H  
**TANSOF Sofa** (beige textured) 78"L 37"D 36"H



## *Key Largo*

**KEYCHR Chair** (black fabric) 35"L 35"D 34"H  
**KEYLOV Loveseat** (black fabric) 57"L 35"D 34"H  
**KEYSOF Sofa** (black fabric) 79"L 35"D 34"H



*Munich*

**MNCHCH Armless Chair** (gray fabric) 22.5"L 27"D 28.5"H  
**MNCHCC Corner Chair** (gray fabric) 26"L 27"D 28.5"H  
**MNCHLA Loveseat** (gray fabric) 45"L 27"D 28.5"H



*Baja*

**BCHWHT Chair** (white vinyl) 36"L 30.5"D 28"H  
**BLVWHT Loveseat** (white vinyl) 61"L 30.5"D 28"H  
**BSFWHT Sofa** (white vinyl) 86"L 30"D 28"H



*Naples* 

**NPLCHP Chair, Powered** (black vinyl) 36"L 30"D 33.25"H  
Also available with standard arm (NPLCHR).  
**NPLLOP Loveseat, Powered** (black vinyl) 62"L 30"D 33.25"H  
Also available with standard arms (NPLLOV).  
**NPLSOP Sofa, Powered** (black vinyl) 87"L 30"D 33.25"H  
Also available with standard arms (NPLSOF).





# Accent Chairs



A.

**A) LABREA La Brea Swivel Chair** (charcoal gray fabric, chrome) 35"L 27"D 40"H  
**B) WENCHA Wentworth Swivel Chair** (brown vinyl, black) 31"L 24"D 31.5"H



B.

## Spin Around.

Swivel chairs in small spaces maximize functionality and allow you to engage with those all around!



C.



D.



E.

**C) OCB Key West Chair** (black fabric, wood) 31"L 31"D 31"H  
**D) BCW Madrid Chair** (white vinyl, chrome) 30"L 30"D 31"H  
**E) PROGB Pro Executive Guest Chair** (black vinyl, chrome) 24"L 22"D 36"H

# *Palm Beach Sofa & Swanson Chairs*

10'x10' Booth



*Swanson*

**SWAN Swivel Chair**  
(white vinyl, chrome) 28"L 25"D 30"H



# Group Seating

## Meeting Chairs

25.5"L 23.5"D 34"H

- A) OCMTAU (taupe fabric, wenge)
- B) OCMWHT (white vinyl, wenge)
- C) OCMESP (espresso vinyl, wenge)



## Marina Chairs

17.5"L 19.5"D 35"H

- A) MARCWH (white vinyl, brushed metal)
- B) MARCBK (black vinyl, brushed metal)
- C) MARCBR (brown fabric, brushed metal)
- D) MARCBE (ocean blue fabric, brushed metal)
- E) MARCRD (red fabric, brushed metal)



**A) CS8 Berlin Chair** (black, white, chrome) 18"L 22"D 32"H  
**B) CS4 Syntax Chair** (black, chrome) 23"L 19"D 32.25"H  
**C) XCHR Christopher Chair** (white vinyl, chrome) 17"L 19"D 35"H  
**D) SC3 Brewer Chair** (onyx, black) 20"L 20"D 32"H  
**E) RSTDIN Rustique Chair w/arms** (gunmetal) 20"L 18"D 31"H  
**F) ZENCHR Zenith Chair** (white, chrome) 18.25"L 22"D 32"H  
**G) LMCHR Laguna Chair** (maple, chrome) 18"L 19"D 34"H

**H) SC10 Razor Armless Chair** (white) 15.5"L 15.5"D 30.5"H  
**I) BLDCSB Blade Chair** (sky blue) 20.5"L 19"D 30.5"H  
**J) BLDCRD Blade Chair** (red) 20.5"L 19"D 30.5"H  
**K) LUCHCL Lucent Chair** (frosted acrylic, chrome) 19.5"L 19.75"D 32.5"H  
**L) DUET Duet Stack Chair** (black, chrome) 21"L 23"D 33"H  
**M) MALGRN Malba Chair** (green, chrome) 20"L 20"D 32"H  
**N) MALGRY Malba Chair** (gray, chrome) 20"L 20"D 32"H



# Cafe Seating & Tables

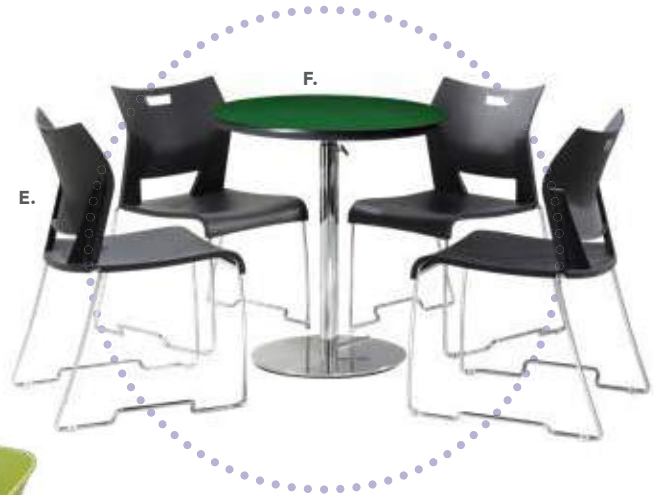

**A) XCHR Christopher Chair**

(white vinyl, chrome) 17"L 19"D 35"H

**B) 30BRHC Hydraulic Cafe Table**

(red top, chrome) 30"RND 29"H

**C) BLDCSB Blade Chair**

(sky blue) 20.5"L 19"D 30.5"H

**D) 30WDHC Hydraulic Cafe Table**

(wood top, chrome) 30"RND 29"H

**E) DUET Duet Stack Chair**

(black, chrome) 21"L 23"D 33"H

**F) 30GSHC Hydraulic Cafe Table**

(green top, chrome) 30"RND 29"H

**G) MALGRN Malba Chair**

(green, chrome) 20"L 20"D 32"H

**H) 30MAHC Madison Hydraulic Cafe Table**

(gray acajou top, chrome) 30"RND 29"H

# Style

your exhibit  
with cafe sets that  
create inviting conference  
and meeting areas for  
your guests.



- A) MARCBR Marina Chair**  
(brown fabric, brushed metal) 17.5"L 19.5"D 35"H
- B) 30WDHC Hydraulic Cafe Table**  
(wood top, chrome) 30"RND 29"H
- C) ZENCHR Zenith Chair**  
(white, chrome) 18.25"L 22"D 32"H
- D) 30MAHC Madison Hydraulic Cafe Table**  
(gray acajou top, chrome) 30"RND 29"H
- E) MALGRY Malba Chair**  
(gray, chrome) 20"L 20"D 32"H
- F) 30BEHC Hydraulic Cafe Table**  
(blue top, chrome) 30"RND 29"H
- G) LMCHR Laguna Chair**  
(maple, chrome) 18"L 19"D 34"H
- H) 30OSHC Hydraulic Cafe Table**  
(orange top, chrome) 30"RND 29"H

# Ottomans

## Vibe Cubes

18"L 18"D 18"H

- A) VIB09 (white vinyl)
- B) VIB10 (black vinyl)
- C) VIB11 (steel blue vinyl)
- D) VIB13 (purple vinyl)
- E) VIB12 (silver vinyl)
- F) VIB04 (red vinyl)
- G) VIB05 (bright yellow vinyl)
- H) VIB15 (taupe vinyl)
- I) VIB02 (blue vinyl)
- J) VIB08 (orange vinyl)
- K) VIB14 (citrus green vinyl)
- L) VIB17 (desert rose vinyl)
- M) VIB16 (spice orange vinyl)
- N) VIB06 (gold/bronze vinyl)
- O) VIB01 (green vinyl)



## Squares

### Endless Square

34"L 34"D 15"H

- A) END02B (black vinyl, chrome)
- B) END02W (white vinyl, chrome)



A.



B.

## Benches

### C) WHT12 Half

(white vinyl)  
39"L 22"D 18"H

### D) REGBEN Regis

(brushed metal)  
47"L 15.5"D 16"H



C.



D.

# Provide a Pop!

Colorful furnishings  
attract attention  
and help reinforce  
brand themes.

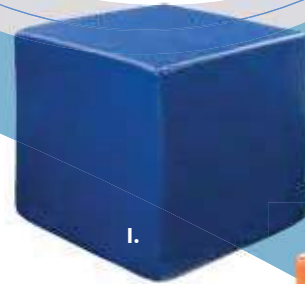
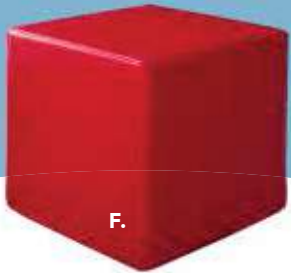
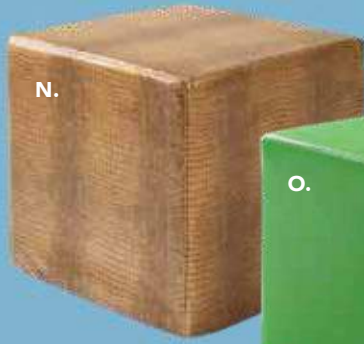

## Curves

**Endless Curved**  
60.5"L 37.5"D 15"H  
**A) END01B**  
(black vinyl, chrome)  
**B) END01W**  
(white vinyl, chrome)



**C) BNQ7**  
**Quarter Curve**  
(white vinyl)  
53"L 22"D 18"H  
**D) BNQR17 Ring**  
(4 ottoman seats)  
(white vinyl)  
72"RND 18"H





# Beverly

**Beverly Bench Ottoman**  
10'x20' Booth



## Demo down.

Rectangular or circular ottomans are a great way to design small theaters for quick demonstrations.



A.



B.



C.



D.



E.



F.



G.

### **Bench Ottomans**

60"L 20"D 18"H

- A) BVLYWH (white vinyl)
- B) BVLYBK (black vinyl)
- C) BVLYGR (gray fabric)
- D) BVLYRD (red fabric)
- E) BVLYOB (ocean blue fabric)
- F) BVLYLN (linen fabric)
- G) BVLYBN (brown fabric)

# Marche

A.



B.



C.



D.



E.



F.



G.



H.



I.



J.



K.



L.



M.



N.



O.



## Swivel Ottomans

17"RND 18"H

- A) MAR001 (white vinyl)
- B) MAR005 (red fabric)
- C) MAR009 (pear yellow fabric)
- D) MAR007 (plum fabric)
- E) MAR010 (blue fabric)
- F) MAR002 (gray fabric)
- G) MAR003 (linen fabric)
- H) MAR004 (raspberry fabric)
- I) MAR008 (meadow green fabric)
- J) MAR011 (orange fabric)
- K) MAR015 (black vinyl)
- L) MAR012 (forest green vinyl)
- M) MAR013 (teal velvet)
- N) MAR014 (distressed brown vinyl)
- O) MAR006 (rose quartz fabric)



Marche Theater 10'x20' Booth

# Accent Table Collections

*Stay Social.*

Stylize furnishings to create shareable moments worthy of Instagram.



## Mesa

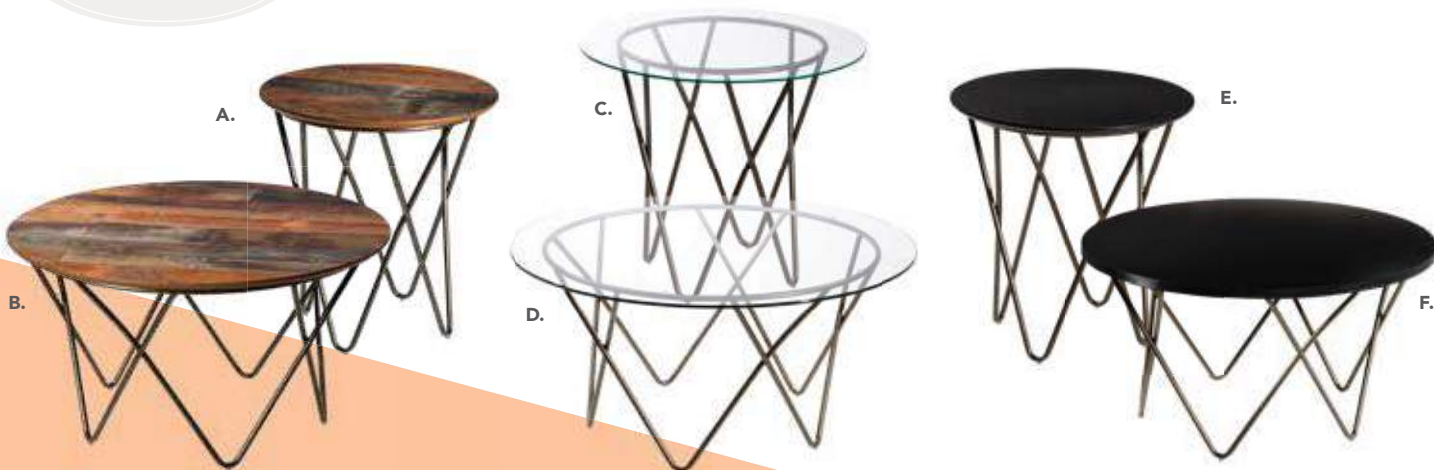

**A) MESETW End Table**  
20.5"RND 21.25"H (wood top, bronze)  
**B) MESCTW Cocktail Table**  
32.25"RND 17.25"H (wood top, bronze)

**C) MESETG End Table**  
24"RND 21.25"H (glass top, bronze)  
**D) MESCTG Cocktail Table**  
36"RND 17.25"H (glass top, bronze)

**E) MESETB End Table**  
20.5"RND 21.25"H (black top, bronze)  
**F) MESCTB Cocktail Table**  
32.25"RND 17.25"H (black top, bronze)

# Alondra

## Cocktail Table

47" L 24" D 16" H

- A) ALC100 (glass top, chrome)
- B) ALC200 (wood top, chrome)

## End Table

20" L 20" D 20" H

- C) ALE100 (glass top, chrome)
- D) ALE200 (wood top, chrome)



# Geo

## Cocktail Table

50" L 22" D 16" H / 47" L 24" D 17" H

- A) C1C (glass top, chrome)
- B) C1FWB (wood top, black)

## End Table

26" L 26" D 20" H / 20" L 20" D 21" H

- C) E1C (glass top, chrome)
- D) E1FWB (wood top, black)



# Accent Tables



## Taos

### Side Tables

15.75"L 15.75"D 24"H

A) TAOBWH (white top, bronze)

B) TAOSBK (black top, bronze)

C) TAOSWD (wood top, bronze)



## Sedona

### Side Tables

15.75"L 15.75"D 24"H

A) SEDBWH (white top, bronze)

B) SEDBSK (black top, bronze)

C) SEDBWD (wood top, bronze)

## Sydney

### Cocktail Tables

48"L 26"D 18"H

A) C1W (white top, brushed steel)

C1WP (powered)

B) C1Y (black top, brushed steel)

C1YP (powered)

C) SYDBEC (blue top, brushed steel)

D) SYDWDC (wood top, brushed steel)

### End Tables

27"L 23"D 22"H

E) E1W (white top, brushed steel)

F) E1Y (black top, brushed steel)

G) SYDBEE (blue top, brushed steel)

H) SYDWDE (wood top, brushed steel)





## Regis

- A) REGBEN Bench Table**  
(brushed metal) 47" L 15.5"D 16"H  
**B) REGOTT End Table**  
(brushed metal) 16" L 15.5"D 16.5"H



## Silverado

- C) E1E End Table**  
(glass top, chrome) 24" RND 22"H  
**D) C1E Cocktail Table**  
(glass top, chrome) 36" RND 17"H



## Rustic

- E) ETBL E-Table**  
(wood) 21" L 15.5"D 27.5"H  
**F) TMBTBL Timber Table**  
(wood) 16" RND 17"H

## Aura

- G) AURA Round Table**  
(white metal) 15" RND 22"H

H.



POWERED  
DETAIL

I.



## Wireless Charging Table

- H) CUBPOW Wireless Charging Table, Powered**  
(white, AC plug-in)  
20" L 20"D 18"H

## Edge

- I) CUBTBL LED Cube Table**  
(plexi top, white plastic)  
20" L 20"D 20"H (AC power only)

# Bar & Cafe Tables

*Style*  
your exhibit  
with **bar and cafe** sets  
that create inviting  
conference and meeting  
areas for your  
guests.

1. Choose Your  
Base: Black  
or Chrome...



## Bar Tables

Standard Black Base  
30" RND 42"H

**VTJ** (graphite nebula top)

**VTK** (maple top)

**VTB** (red top)

**30WH42** (white top)

**VTA** (Madison/gray acajou top)

**30BEBB** (blue top)

**30WDDB** (wood top)

**30BKSB** (black top)

**30AGBB** (brushed gunmetal top)

**30OSBB** (orange top)

**30YBBB** (brushed yellow top)

**30GSBB** (green top)

36" RND 42"H

**VTW** (white top)

**VTN** (graphite nebula top)

**VTP** (maple top)

**36BKSB** (black top)

## Bar Tables

Hydraulic Chrome Base

30" RND 45"H

**30GRHB** (graphite nebula top)

**30MTHB** (maple top)

**30BRHB** (red top)

**30WHHB** (white top)

**30MAHB** (Madison/gray acajou top)

**30BEHB** (blue top)

**30WDHB** (wood top)

**30BKHB** (black top)

**30AGHB** (brushed gunmetal top)

**30OSHB** (orange top)

**30YSHB** (brushed yellow top)

**30GSHB** (green top)

36" RND 45"H

**36WTHB** (white)

**36GRHB** (graphite nebula)

**36MTHB** (maple top)

**36BKHB** (black top)

**HDG4FT**  
**Boxwood Hedge, 4'**  
46"L 9"D 47"H



**RSTSQT**  
**Rustique Square**  
**Metal Bar Table**  
(gunmetal)  
23.75"L 23.75"D 41.25"H

**LMBAR**  
**Laguna Barstool**  
(maple, chrome)  
18"L 20"D 47"H



## 2. Then pick a color that suits your design.



### Cafe Tables

Standard Black Base

30" RND 29"H

**ZTJ** (graphite nebula top)

**ZTK** (maple top)

**30WH29** (white top)

**ZTB** (red top)

**ZTA** (Madison/gray acajou top)

**30BEBC** (blue top)

**30WDDBC** (wood top)

**30AGBC** (brushed gunmetal top)

**30BKSC** (black top)

**30OSBC** (orange top)

**30YSBC** (brushed yellow top)

**30GSBC** (green top)

36" RND 29"H

**ZTQ** (white top)

**ZTN** (graphite nebula top)

**ZTP** (maple top)

**36BKSC** (black top)

### Cafe Tables

Hydraulic Chrome Base

30" RND 29"H

**30GRHC** (graphite nebula top)

**30MTHC** (maple top)

**30BRHC** (red top)

**30MAHC** (Madison/gray acajou top)

**30WHHC** (white top)

**30BEHC** (blue top)

**30WDHC** (wood top)

**30AGHC** (brushed gunmetal top)

**30BKHC** (black top)

**30OSHC** (orange top)

**30YSHC** (brushed yellow top)

**30GSHC** (green top)

36" RND 29"H

**36WTHC** (white top)

**36GRHC** (graphite nebula top)

**36MTHC** (maple top)

**36BKHC** (black top)

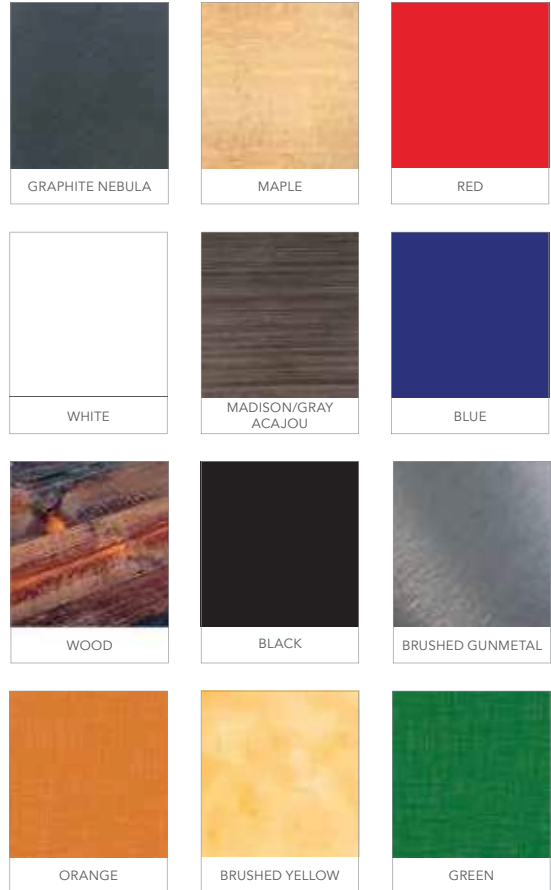

### CS4 Syntax Chair

(black, chrome)

23"L 19"D 32.25"H





# Barstool Collection

*Spin 360°*

Use barstools  
to maximize client  
engagement with those  
all around you.

*Zoey*

15"L 16"D 30-34.75"H

A) BS003 (black, chrome)

B) BS002 (white, chrome)

A.



B.



# Lift

15"RND 23-33.5"H

**A) ROLLWH** (white vinyl, chrome)

**B) ROLLRD** (red vinyl, chrome)

**C) ROLLBL** (black vinyl, chrome)

**D) ROLLGY** (gray vinyl, chrome)



# Barstool Collection



## Banana

21"L 22"D 41"H

- A) BSS Barstool (black, chrome)
- B) BST Barstool (white, chrome)



## Zenith

ZENBAR Barstool

(white, chrome) 19"L 20"D 44"H



## Apex

21"L 21"D 33"H

- A) APS08 Barstool (black vinyl, silver)
- B) APS59 Barstool (red vinyl, silver)
- C) APS75 Barstool (white vinyl, silver)
- D) APS12 Barstool (blue ultra suede, silver)





A.



B.



C.

**A) BSC Oslo Barstool**

(white, chrome) 17"L 20"D 45"H

**B) XBAR Christopher Barstool**

(white vinyl, chrome) 19"L 15"D 41"H

**C) BS001 Shark Barstool**

(white, chrome) 22"L 19"D 34-44"H

**D) BSR Syntax Barstool**

(black, chrome) 23"L 19"D 43.25"H

**E) RSTSTL Rustique Barstool**

(gunmetal) 13"L 13"D 30"H

**F) LUBSCL Lucent Barstool**

(frosted acrylic, chrome)

22"L 22.5"D 45.5"H

**G) LMBAR Laguna Barstool**

(maple, chrome) 18"L 20"D 47"H



D.



E.



F.



G.

*Blade*

20.5"L 20"D 40.5"H

**H) BLDBRD Barstool (red)**

**I) BLDBSB Barstool (sky blue)**



H.



I.

# Office Essentials





*Create*  
comfortable  
productive environments  
in your booth or temporary  
show office with on-trend  
furnishings that reflect  
your sense of  
style.

# Conference Tables

**42" Round Conference Table 42" RND 29"H**

- A) CONF42** (white top, black)
- B) CB1** (graphite nebula top, black)
- C) CB8** (Madison/gray acajou top, black)
- D) 42BKCT** (black top, black)



## Madison

(gray acajou top, chrome)

- E) MADC05 5' Table** 60"L 48"D 29"H
- F) MADC08 8' Table** 96"L 60"D 29"H
- G) MADC10 10' Table** 120"L 48"D 29"H



H.



G.

I.

- H) CUPCHA Cupertino Mid Back Chair**  
(black vinyl, chrome) 27"L 30.5"D 40-43"H Adjustable.
- I) GENCHA Genesis Chair**  
(black fabric, black) 27.5"L 27.5"D 40-43.5"H Adjustable.

# Table Side.

Incorporate conference tables to facilitate booth meetings and new connections.

**Atomic Round Tables** (glass, chrome)  
**42ATO** 42"RND 30"H  
**36ATO** 36"RND 30"H



**PROGB**  
**Pro Guest Chair**  
 (black vinyl)  
 24"L 22"D 36"H



**Geo Rounded Square Tables**  
 42"L 42"D 29"H  
**A) CE1** (glass top, chrome)  
**B) CF1** (glass top, black)

**Geo Rectangular Tables**  
 60"L 36"D 29"H  
**C) CF2** (glass top, black)  
**D) CE2** (glass top, chrome)



**E) MERLIN Merlin Multi Use Table**  
 (gray top, black)  
 46"L 29"D 30"H  
**F) WD3 Work Table**  
 (white top, white)  
 48"L 24"D 30"H



**Conference Tables**  
 (graphite nebula top, black)  
**G) CB3 8'**  
 96"L 48"D 29"H  
**H) CB2 6'**  
 72"L 42"D 29"H



**Conference Tables**  
 (granite top, black)  
**I) C508GR 8'**  
 96"L 44"D 29"H  
**J) CT10GR 10'**  
 120"L 46"D 29"H  
**K) CT06GR 6'**  
 72"L 36"D 29"H



# Executive Seating & Desks

## Cupertino



**CUPCHA Mid Back Chair**  
(black vinyl, chrome)  
27"L 30.5"D 40-43"H  
Adjustable height

## Pro High Back



**Executive Chairs**  
25"L 24"D 45-48"H  
Adjustable height  
**A) PROEXE** (white vinyl, chrome)  
**B) PROEXB** (black vinyl, chrome)

## Pro Mid Back



**Executive Chairs**  
24"L 22"D 36.75-39.75"H  
Adjustable height  
**C) PROMID** (white vinyl, chrome)  
**D) PROMDB** (black vinyl, chrome)

## Pro Guest



**PROGB Executive Chair**  
(black vinyl, chrome)  
24"L 26"D 36"H

## Task



**TASKST Stool**  
(black fabric, black)  
27.5"L 27.5"D 32.75"-40.25"H  
Adjustable height

## Genesis



**GENCHA Chair**  
(black fabric, black)  
27.5"L 27.5"D 40-43.5"H  
Adjustable height

# Madison

- A) JD8 Executive Desk (gray acajou) 60"L 30"D 29"H
- B) CR8 Credenza (gray acajou) 60"L 20"D 29"H
- C) BC8 Bookcase (gray acajou) 36"L 12"D 72"H

A. DESK FRONT



DESK BACK



B. CREDENZA FRONT



CREDENZA BACK



C.



# Tech Desk

- A) TECH3B Desk, Powered, w/3 Drawer File Cabinet (black top, black metal) 60"L 30"D 30"H
- B) TECH Desk, Powered (black top, black metal) 60"L 30"D 30"H
- C) TECH3 3 Drawer File Cabinet on Castors (black top, black metal) 16"L 20"D 28"H

A. 

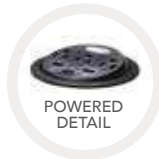

POWERED  
DETAIL

B. 



C.



# Ventura

## Powered & Communal Tables



Table Top Options **BLACK** **WHITE** **MAPLE**  
 Colors not available in all table options. Please check options listed.



**Powered Bar Tables**  
 72.25"L 26.25"D 42"H  
 (silver frame)

**A) VNTBLK** (black top)  
**VNTWHT** (white top)

**Communal Bar Tables**  
 72.25"L 26.25"D 42"H  
 (silver frame)

Maple Top  
**B) VNTMNP** (solid)  
**VNTBMW** (grommets)

White Top  
**C) VNTBWW** (grommets)  
**VNTWNP** (solid)

Black Top  
**VNTBNP** (solid)

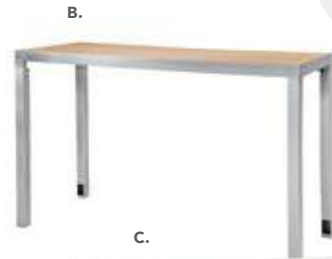

*Draw A Crowd.*  
 Communal tables keep attendees charged while encouraging networking and genuine connections.



**Powered Cafe Tables**  
 72.25"L 26.25"D 30"H  
 (silver frame)

**A) VNTCBK** (black top)  
**B) VNTCWH** (white top)

**Communal Cafe Tables**  
 72.25"L 26.25"D 30"H  
 (silver frame)

Maple Top  
**C) VNTCMN** (solid)  
**VNTCMW** (grommets)

White Top  
**D) VNTCWW** (grommets)  
**VNTCWN** (solid)

Black Top  
**E) VNTCBN** (solid)

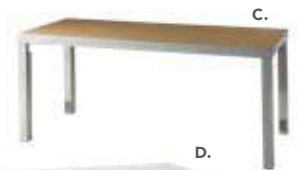

# Office Accessories & Decor

Powered Products



A.



B.



LED light available in white, red, green, blue and rolling color.



C.



D.

**Mason Lamps**  
(brushed silver)

**A) LA15 Floor Lamp**

18" RND 55"H

**B) LA14 Table Lamp**

16" RND 26"H

**C) CUBL20**

**Edge LED Cube Ottoman**

(white plastic)

20"L 20"D 20"H

(AC power only)

**D) CUBTBL**

**Edge LED Cube Table**

(plexi top, white plastic)

20"L 20"D 20"H

(AC power only)

## Go Biophilic

It's easy to be green.  
Just add greenery to your booth environment  
for a warm and natural feel.



A.



B.



C.

**A) PSHCCS**

**Posh Shelving**

(chrome, acrylic)

36"L 18"D 72"H

**B) HDG7FT**

**Boxwood Hedge, 7'**

36.5"L 12"D 84"H

**C) HDG4FT**

**Boxwood Hedge, 4'**

46"L 9"D 47"H

# Midtown

## Counter & Bar



**Midtown Powered Counter**  
 60"L 18"D 42"H (taupe glass top, pewter)  
**MTCPUL** (unlighted)  
**MTCLPI** (lighted with plug-in)

Metallic pewter gray curved counter with taupe-colored glass top features two AC & three USB charging outlets, locking storage cabinet and two shelves.



**HDG7FT**  
**Boxwood Hedge, 7'**  
 36.5"L 12"D 84"H



**BLDBSB Blade Barstool**  
 20.5"L 20"D 40.5"H  
 (sky blue)



**Midtown Bar**  
 60"L 18"D 42"H (taupe glass top, pewter)  
**A) MTBUUL** (unlighted)  
**B) MTBLPI** (lighted with plug-in)

Metallic pewter gray curved bar with taupe-colored glass top features locking cabinet for storage and two shelves.



(back)





# Cocktail and Occasional Tables

## AFCEA Belvoir PEO Industry Days

Gaylord National Resort & Convention Ctr (Prince George Exhibits) - National Harbor, MD

November 17 - 18, 2020

**Discount Deadline Tuesday, October 27, 2020**

Order with complete Payment Authorization must be received before Discount Deadline date to receive discounted pricing.

Event Code: M145781120  
 email: [baltimore@shepardes.com](mailto:baltimore@shepardes.com)  
 phone: (410) 737-9270  
 fax: (410) 737-9274

### Cocktail Tables

Qty.	Item	Discount	Regular	Amount
	C1E-Silverado	\$430.10	\$559.15	
	ALC100-Alondra, Glass/Chrome	\$518.45	\$674.00	
	ALC200-Alondra, Wood/Chrome	\$518.45	\$674.00	
	C1FWB-Geo, Wood/Black	\$453.65	\$589.75	
	C1C-Geo Rect., Glass/Chrome	\$388.85	\$505.50	
	MESCTB-Mesa Cocktail Table Black top	\$300.30	\$390.40	
	MESCTG-Mesa Cocktail Table Glass top	\$300.30	\$390.40	
	MESCTW-Mesa Cocktail Table Wood top	\$300.30	\$390.40	
	C1W-Sydney, White	\$435.95	\$566.75	
	C1WP-Sydney White, <b>Powered!</b>	\$553.80	\$719.95	
	C1Y-Sydney, Black	\$435.95	\$566.75	
	C1YP-Sydney Black, <b>Powered!</b>	\$553.80	\$719.95	
	REGBEN-Regis Bench Table	\$444.80	\$578.25	
	SYDBEC-Sydney Cocktail Table	\$441.85	\$574.40	
	SYDWDC-Sydney Cocktail Table	\$401.70	\$522.20	

### Occasional End Tables

Qty.	Item	Discount	Regular	Amount	Qty.	Item	Discount	Regular	Amount
	E1E-Silverado	\$409.45	\$532.30			TAOBWH-Taos White top	200.2	260.25	
	ALE100-Alondra, Glass/Chrome	\$374.15	\$486.40			TAOBK Taos Black top	200.2	260.25	
	ALE200-Alondra, Wood/Chrome	\$374.15	\$486.40			TAOBWD Taos Wood top	200.2	260.25	
	E1FWB-Geo, Wood/Black	\$394.75	\$513.20			SEDBWH Sedona White top	200.2	260.25	
	E1C-Geo, Glass/Chrome	\$383.00	\$497.90			SEDBK Sedona Black Top	200.2	260.25	
	MESETB-Mesa End Table, Black top	\$198.40	\$257.90			SEDBWD Sedona Wood Top	200.2	260.25	
	MESETG-Mesa End Table, Glass top	\$198.40	\$257.90						
	MESETW-Mesa End Table, Wood top	\$198.40	\$257.90						
	E1W-Sydney, White	\$394.75	\$513.20						
	E1Y-Sydney, Black	\$394.75	\$513.20						
	CUBTBL-Edge LED Cube	\$306.35	\$398.25						
	AURA End Table	\$223.85	\$291.00						
	ETBL-E Table, Wood	\$276.90	\$359.95						
	TMBTBL Timber Table, Wood	\$265.15	\$344.70						
	REGOTT-Regis End Table	\$327.00	\$425.10						
	CUBPOW-Wireless Chrg Tbl, <b>Powered!</b>	\$666.85	\$866.90						
	SYDBEE - Sydney End Table	\$388.30	\$504.80						
	SYDWDE-Sydney End Table	\$388.30	\$504.80						

Submission of this form indicates you read and accept the Payment Policy and Terms & Conditions.

Total Exec Tables Furnishings: \$ \_\_\_\_\_

There are no exchanges or refunds once item has been delivered to your booth. Cancellations must be received in writing within 14 days prior to first exhibitor move in day.

6.000% Tax\*: \$ \_\_\_\_\_

Amount Due: \$ \_\_\_\_\_

Rental items found and in use in your booth are subject to "Regular" pricing.

Company Name: \_\_\_\_\_ Booth # \_\_\_\_\_

Contact Name \_\_\_\_\_

Email: \_\_\_\_\_

Signature: \_\_\_\_\_



**AFCEA Belvoir PEO Industry Days**

Gaylord National Resort & Convention Ctr (Prince George Exhibits) - National Harbor, MD

November 17 - 18, 2020

**Discount Deadline Tuesday, October 27, 2020**

Order with complete Payment Authorization must be received before Discount Deadline date to receive discounted pricing.

Event Code: M145781120  
 email: [baltimore@shepardes.com](mailto:baltimore@shepardes.com)  
 phone: (410) 737-9270  
 fax: (410) 737-9274

**Styles and Shapes**

Qty.	Item	Discount	Regular	Amount
	END02B-Square, Black Leather	\$406.50	\$528.45	
	END02W-Square, White Leather	\$406.50	\$528.45	
	END01B-Curved, Black Leather	\$648.05	\$842.45	
	END01W-Curved, White Leather	\$648.05	\$842.45	
	CUBL20-Edge Lighted Cube	\$306.35	\$398.25	
	WHT12-Half Bench, White Vinyl	\$583.25	\$758.25	
	BNQ7-Quarter Curve, White Vinyl	\$762.95	\$991.85	
	BNQR17-Ottoman Ring, White Vinyl	\$2,733.70	\$3,553.80	
	REGBEN Regis Bench, Brushed Metal	\$444.80	\$578.25	

**Beverly Bench**

Qty.	Item	Discount	Regular	Amount
	BVLYBK Bev Bench Black Vinyl	\$624.50	\$811.85	
	BVLYBN Bev Bench Brown Fabric	\$624.50	\$811.85	
	BVLYGR Bev Bench Grey Fabric	\$624.50	\$811.85	
	BVLYLN Bev Bench Linen Fabric	\$624.50	\$811.85	
	BVLYOB Bev Bench Ocean Fabric	\$624.50	\$811.85	
	BVLYRD Bev Bench Red Fabric	\$624.50	\$811.85	
	BVLYWH Bev Bench White Vinyl	\$624.50	\$811.85	

**Marche Swivel**

Qty.	Item	Discount	Regular	Amount
	MAR001-Marche Swivel, White	\$288.65	\$375.25	
	MAR002-Marche Swivel, Grey	\$288.65	\$375.25	
	MAR003-Marche Swivel, Linen	\$288.65	\$375.25	
	MAR004-Marche Swivel, Raspberry	\$288.65	\$375.25	
	MAR005-Marche Swivel, Red	\$288.65	\$375.25	
	MAR006-Marche Swivel, Rose Qtz	\$288.65	\$375.25	
	MAR007-Marche Swivel, Plum	\$288.65	\$375.25	
	MAR008-Marche Swivel, Mdw Grn	\$288.65	\$375.25	
	MAR009, Marche Swivel, Pear	\$288.65	\$375.25	
	MAR010-Marche Swivel, Blue	\$288.65	\$375.25	
	MAR011-Marche Swivel, Orange	\$288.65	\$375.25	
	MAR012-Marche Swivel, Forest Green	\$288.65	\$375.25	
	MAR013-Marche Swivel, Teal Velvet	\$288.65	\$375.25	
	MAR014-Marche Swivel, Distr. Brown	\$288.65	\$375.25	
	MAR015-Marche Swivel, Black Vinyl	\$288.65	\$375.25	

**Vibes**

Qty.	Item	Discount	Regular	Amount
	VIB01-Vibe Cube, Green	\$218.00	\$283.40	
	VIB02-Vibe Cube, Blue	\$218.00	\$283.40	
	VIB04-Vibe Cube, Red	\$218.00	\$283.40	
	VIB05-Vibe Cube, Yellow	\$218.00	\$283.40	
	VIB06-Vibe Cube, Gold/Bronze	\$218.00	\$283.40	
	VIB08-Vibe Cube, Orange	\$218.00	\$283.40	
	VIB09-Vibe Cube, White Wtrproof	\$218.00	\$283.40	
	VIB10-Vibe Cube, Black Wtrproof	\$218.00	\$283.40	
	VIB11 Vibe Cube, Steel Blue Vinyl	\$218.00	\$283.40	
	VIB12 Vibe Cube, Silver Vinyl	\$218.00	\$283.40	
	Vibe13-Vibe Cube, Purple Vinyl	\$218.00	\$283.40	
	Vibe14-Vibe Cube, Cirtus Green	\$218.00	\$283.40	
	Vibe15-Vibe Cube, Taupe Vinyl	\$218.00	\$283.40	
	Vibe16- Vibe Cube, Spice Orange	\$218.00	\$283.40	
	Vibe 17-Desert Rose	\$218.00	\$283.40	

Submission of this form indicates you read and accept the Payment Policy and Terms & Conditions.

There are no exchanges or refunds once item has been delivered to your booth. Cancellations must be received in writing within 14 days prior to first exhibitor move in day.

Rental items found and in use in your booth are subject to "Regular" pricing.

Total Ottomans: \$ \_\_\_\_\_  
 6.000% Tax\*: \$ \_\_\_\_\_  
 Amount Due: \$ \_\_\_\_\_

Company Name: \_\_\_\_\_ Booth # \_\_\_\_\_

Contact Name \_\_\_\_\_

Email: \_\_\_\_\_

Signature: \_\_\_\_\_



**AFCEA Belvoir PEO Industry Days**

Gaylord National Resort & Convention Ctr (Prince George Exhibits) - National Harbor, MD

November 17 - 18, 2020

**Discount Deadline Tuesday, October 27, 2020**

Order with complete Payment Authorization must be received before Discount Deadline date to receive discounted pricing.

Event Code: M145781120  
 email: [baltimore@shepardes.com](mailto:baltimore@shepardes.com)  
 phone: (410) 737-9270  
 fax: (410) 737-9274

**Sofas and Sectionals**

Qty.	Item	Discount	Regular	Amount
	MNCHSC Munich Sectional, 3 pc	\$2,878.05	\$3,741.45	
	SFA002- Allegro Sofa	\$1,084.05	\$1,409.25	
	NPLSOF-Naples Sofa, Black Vinyl	\$1,296.15	\$1,685.00	
	VALSOF- Valencia Sofa	\$689.80	\$896.75	
	TANSOF-Tangiers Sofa, Beige	\$1,028.10	\$1,336.55	
	KEYSOF-Key Largo Sofa	\$733.50	\$953.55	
	FAIRSW-Fairfax Sofa	\$739.40	\$961.20	
	BSFWHT-Baja Sofa	\$1,312.20	\$1,705.85	
	PALSOF-Palm Beach Sofa	\$1,029.60	\$1,338.50	

**Accent Chairs**

Qty.	Item	Discount	Regular	Amount
	SWAN-Swanson Swivel, White Vinyl	\$553.80	\$719.95	
	OCB-Key West Tub, Black	\$615.70	\$800.40	
	BCW-Madrid Chair, White	\$1,157.70	\$1,505.00	
	LABREA-La Brea Swivel Chair	\$636.30	\$827.20	
	VALCHA Valencia Chair	\$464.10	\$603.35	
	MNCHCC Munich Corner Chair	\$874.90	\$1,137.35	
	MNCHCH Munich Armless Chair	\$721.70	\$938.20	
	OCH Madrid Chair, Black	\$1,157.70	\$1,505.00	
	WENCHA-Wentworth Chair	\$508.80	\$661.45	

**Loveseats**

Qty.	Item	Discount	Regular	Amount
	KEYLOV-Key Largo Loveseat	\$568.55	\$739.10	
	TANLOV Tangiers Loveseat	\$1,072.25	\$1,393.95	
	BLVWHT Baja Loveseat White Vinyl	\$1,234.30	\$1,604.60	
	MNCHLV- Munich Armless Loveseat	\$1,281.40	\$1,665.80	
	NPLLOV- Naples Loveseat, Blk Vinyl	\$1,089.90	\$1,416.85	

**Meeting Chairs**

Qty.	Item	Discount	Regular	Amount
	OCMTAU-Meeting Chair, Taupe	\$424.20	\$551.45	
	OCMWHT-Meeting Chair, White	\$388.85	\$505.50	
	OCMESP-Meeting Chair, Espresso	\$430.10	\$559.15	

**Club Chairs**

Qty.	Item	Discount	Regular	Amount
	BCHWHT Baja Chair, White Vinyl	\$842.55	\$1,095.30	
	NPLCHR-Naples Chair, Black Vinyl	\$904.35	\$1,175.65	
	TANCHR-Tangiers Chair, Beige	\$668.70	\$869.30	
	CHR002-Allegro Chair	\$760.05	\$988.05	
	KEYCHR-Key Largo Chair	\$486.05	\$631.85	
	FAIRCW-Fairfax Chair	\$533.20	\$693.15	

**Modular System**

Qty.	Item	Discount	Regular	Amount
	BNQ417-Full Banquette- <b>Powered!</b>	\$3,555.55	\$4,622.20	
	BNQR17-Ottoman Ring, White Vinyl	\$2,733.70	\$3,553.80	
	BNQ7-Quarter Curve, White Vinyl	\$762.95	\$991.85	
	BNQTL7- Center Cone, White Vinyl	\$1,122.35	\$1,459.05	
	WHT12-Half Bench, White Vinyl	\$583.25	\$758.25	

**Powered Seating**

Qty.	Item	Discount	Regular	Amount
	CHRPWR- Roma Chair, powered	\$981.00	\$1,275.30	
	SFAPWR-Roma Sofa, powered	\$1,579.00	\$2,052.70	
	NPLCHP-Naples Chair, powered	\$981.00	\$1,275.30	
	NPLSOP-Naples Sofa, powered	\$1,579.00	\$2,052.70	
	NPLLOP-Naples Loveseat, powered	\$1,358.05	\$1,765.45	

Submission of this form indicates you read and accept the Payment Policy and Terms & Conditions.

There are no exchanges or refunds once item has been delivered to your booth. Cancellations must be received in writing within 14 days prior to first exhibitor move in day.

Rental items found and in use in your booth are subject to "Regular" pricing.

Total Soft Seating: \$ \_\_\_\_\_  
 6.000% Tax\*: \$ \_\_\_\_\_  
 Amount Due: \$ \_\_\_\_\_

Company Name: \_\_\_\_\_ Booth # \_\_\_\_\_

Contact Name \_\_\_\_\_

Email: \_\_\_\_\_

Signature: \_\_\_\_\_





**AFCEA Belvoir PEO Industry Days**

Gaylord National Resort & Convention Ctr (Prince George Exhibits) - National Harbor, MD

November 17 - 18, 2020

**Discount Deadline Tuesday, October 27, 2020**

Order with complete Payment Authorization must be received before Discount  
Deadline date to receive discounted pricing.

Event Code: M145781120  
email [baltimore@shepardes.com](mailto:baltimore@shepardes.com)  
phone (410) 737-9270  
fax (410) 737-9274

**Conference Tables**

**Group & Guest Seating**

Qty.	Item	Discount	Regular	Amount	Qty.	Item	Discount	Regular	Amount
	CF2-Geo Table, Black	\$698.15	\$907.60			Duet-Black, Chrome	\$100.15	\$130.20	
	CE1-Geo Table, Sq. Chrome	\$491.90	\$639.45			RSTDIN-Rustique w/ arms, Gunmetal	\$203.25	\$264.25	
	CF1-Geo Table, Sq. Black	\$491.90	\$639.45			CS8-Berlin Chair, Black	\$197.35	\$256.55	
	CE2-Geo Table, Chrome	\$698.15	\$907.60			XCHR-Christopher Chr, White Vinyl	\$162.05	\$210.65	
	CB2-6' Graphite Table	\$733.50	\$953.55			SC10 Razor Chair	\$120.75	\$157.00	
	CB3-8' Graphite Table	\$863.15	\$1,122.10			SC3-Brewer Chair, Onyx	\$271.00	\$352.30	
	CB1-42" Round, Graphite Nebula	\$595.10	\$773.65			LMCHR-Laguna Chair, Maple/Chrome	\$229.80	\$298.75	
	C508GR-8', Granite	\$863.15	\$1,122.10			MALGRY-Malba Chair, Grey	\$176.75	\$229.80	
	CT10GR-10', Granite	\$1,296.15	\$1,685.00			MALGRN-Malba Chair, Green	\$176.75	\$229.80	
	CT06GR-6', Granite	\$733.50	\$953.55			CS4-Syntax Chair, Black/Chrome	\$321.10	\$417.45	
	PWRUSB-Powered Table Module	\$117.85	\$153.20			ZENCHR-Zenith Chair-White/Chrome	\$259.20	\$336.95	
	CB8-42" Round Madison, Grey	\$526.00	\$683.80			BLDCRD-Blade Chair	\$104.45	\$135.80	
	MADC10-10' Madison, Grey	\$1,487.65	\$1,933.95			BLDCSB-Blade Chair	\$104.45	\$135.80	
	MADC05-5' Madison, Grey	\$745.30	\$968.90			LUCHCL-Lucent Chair	\$281.20	\$365.55	
	MADC08-8' Madison, Grey	\$1,487.65	\$1,933.95			MARCBE-Marina Chair, Ocn Blue	\$227.65	\$295.95	
	CONF42-42" Round, White lam	\$595.10	\$773.65			MARCBK-Marina Chair, Black Vnyl	\$227.65	\$295.95	
	36ATO Atomic 36" Round, Glass	\$491.90	\$639.45			MARCBR-Marina Chair, Brown	\$227.65	\$295.95	
	42ATO Atomic 42" Round, Glass	\$491.90	\$639.45			MARCRD-Marina Chair, Red	\$227.65	\$295.95	
	42BKCT 42" Round, Black Top	\$540.80	\$703.05			MARCWH-Marina Chair, White Vnyl	\$227.65	\$295.95	

**Executive Seating**

Qty.	Item	Discount	Regular	Amount	Qty.	Item	Discount	Regular	Amount
	PROEXE-Pro Executive Chair	\$574.40	\$746.70			TASKST-Task Stool	\$227.65	\$295.95	
	PROEXB-Executive Chair High Back	\$574.40	\$746.70			CUPCHA-Cupertino Mid Back Chair	\$429.00	\$557.70	
	PROGB-Guest Executive Chair	\$403.60	\$524.70			GENCHA-Genesis	\$374.40	\$486.70	
	PROMDB-Exec Mid-Back, Black	\$377.05	\$490.15						
	PROMID-Executive Chair Mid Back	\$365.30	\$474.90						

Submission of this form indicates you read and accept the Payment Policy and Terms & Conditions.

There are no exchanges or refunds once item has been delivered to your booth. Cancellations must be received in writing within 14 days prior to first exhibitor move in day.

Rental items found and in use in your booth are subject to "Regular" pricing.

Total Conference: \$ \_\_\_\_\_  
6.000% Tax\*: \$ \_\_\_\_\_  
Amount Due: \$ \_\_\_\_\_

Company Name: \_\_\_\_\_ Booth # \_\_\_\_\_

Contact Name \_\_\_\_\_

Email: \_\_\_\_\_

Signature: \_\_\_\_\_



# Café and Communal Tables

## AFCEA Belvoir PEO Industry Days

Gaylord National Resort & Convention Ctr (Prince George Exhibits) - National Harbor, MD

November 17 - 18, 2020

**Discount Deadline Tuesday, October 27, 2020**

Order with complete Payment Authorization must be received before Discount Deadline date to receive discounted pricing.

Event Code: M145781120  
 email: [baltimore@shepardes.com](mailto:baltimore@shepardes.com)  
 phone: (410) 737-9270  
 fax: (410) 737-9274

### Café Tables

#### Café Tables- Black Base

Qty.	Item	Discount	Regular	Amount
	ZTK-30" Maple Top/Black Base	\$347.60	\$451.90	
	ZTP-36" Maple Top/Black Base	\$380.00	\$494.00	
	ZTJ-30" Graphite Top/Black Base	\$347.60	\$451.90	
	ZTN-36" Graphite Top/Black Base	\$380.00	\$494.00	
	ZTQ-36" White Laminate Top	\$380.00	\$494.00	
	ZTB-30" Red Top/Black Base	\$347.60	\$451.90	
	ZTA-30" Grey Top/Black Base	\$359.40	\$467.20	
	30WH29 -30" White Laminate	\$368.25	\$478.75	
	30BEBC-30" Blue Top/Black Base	\$348.15	\$452.60	
	30WDBC-30" Wood Top/Black Bas	\$348.15	\$452.60	
	30AGBC-30" Gunmetal/Black base	\$348.15	\$452.60	
	36BKSC-36" Black Top/Black Base	\$380.00	\$494.00	
	30AGBC 30" Brushed Gunmetal/Blk Ba	\$348.15	\$452.60	
	30BKSC 30"Blacktop/Black Base	\$348.15	\$452.60	
	30OSBC 30" Orange Top/Black Base	\$348.15	\$452.60	
	30GSBC 30" Green Top/Black Base	\$348.15	\$452.60	
	30YSBC 30" Brushed Yellow/Black Bas	\$348.15	\$452.60	

#### Café Tables - Chrome Base 30", Hydraulic

Qty.	Item	Discount	Regular	Amount
	30MTHC-Maple Top, Chrome	\$465.45	\$605.10	
	30GRHC-Graphite Nebula, Chrome	\$465.45	\$605.10	
	30BRHC-Brushed Red Top, Chrome	\$465.45	\$605.10	
	30MAHC-Grey Top, Chrome	\$465.45	\$605.10	
	30WHHC-White Laminate	\$503.75	\$654.90	
	30BEHC-Blue Top, Chrome	\$468.65	\$609.25	
	30WDHC-Wood Top, Chrome	\$468.65	\$609.25	
	30BKHC-Black Top, Chrome	\$468.00	\$608.40	
	30AGHC-Brushed Gunmetal, Chrome	\$468.00	\$608.40	
	30YSHC-Brushed Yellow Top, Chrd	\$468.00	\$608.40	
	30GSHC-Green Top, Chrome	\$468.00	\$608.40	
	30OSHC-Orange Top, Chrome	\$468.00	\$608.40	

### G30 and Ventura Communal Tables

#### 30" High Tables

Qty.	Item	Discount	Regular	Amount
	VNTCBN-Black Top, Silver Frame	\$790.00	\$1,027.00	
	VNTCMN-Maple Top, Silver Frame	\$790.00	\$1,027.00	
	VNTCWN-White Top, Silver Frame	\$790.00	\$1,027.00	
	VNTCMW-Maple, w/ Grmt	\$790.00	\$1,027.00	
	VNTCWW-White, w/ Grmt	\$790.00	\$1,027.00	
	VNTCBK-Black Top- <b>Powered!</b>	\$897.15	\$1,166.30	
	VNTCWH-White Top- <b>Powered!</b>	\$897.15	\$1,166.30	

#### Café Tables - Chrome Base 36", Hydraulic

	36MTHC-Maple Top, Chrome	\$506.70	\$658.70	
	36GRHC-Graphite Nebula, Chrome	\$506.70	\$658.70	
	36WTHC-White Top, Chrome	\$506.70	\$658.70	
	36BKHC Black Top, Chrome	\$506.70	\$658.70	

#### 42" High Tables

	VNTBNP Communal Table Black Top	\$1,028.10	\$1,336.55	
	VNTMNP Communal Table Maple Top	\$1,028.10	\$1,336.55	
	VNTWNP Communal Table White Top	\$1,028.10	\$1,336.55	
	VNTBMW Comm Table Maple Top w/ Grom	\$1,028.10	\$1,336.55	
	VNTBWW Comm Table White w/ Grom	\$1,028.10	\$1,336.55	

#### Powered! 42" High Tables

Qty.	Item	Discount	Regular	Amount
	VNTBLK Communal Table Black Top	\$1,213.70	\$1,577.80	
	VNTWHT Communal Table White Top	\$1,213.70	\$1,577.80	

Submission of this form indicates you read and accept the Payment Policy and Terms & Conditions.

There are no exchanges or refunds once item has been delivered to your booth. Cancellations must be received in writing within 14 days prior to first exhibitor move in day.

Rental items found and in use in your booth are subject to "Regular" pricing.

Total Cafe: \$ \_\_\_\_\_  
 6.000% Tax\*: \$ \_\_\_\_\_  
 Amount Due: \$ \_\_\_\_\_

Company Name: \_\_\_\_\_ Booth # \_\_\_\_\_  
 Contact Name \_\_\_\_\_  
 Email: \_\_\_\_\_  
 Signature: \_\_\_\_\_



# Bar Tables, Barstools, Bars

## AFCEA Belvoir PEO Industry Days

Gaylord National Resort & Convention Ctr (Prince George Exhibits) - National Harbor, MD

November 17 - 18, 2020

**Discount Deadline Tuesday, October 27, 2020**

Order with complete Payment Authorization must be received before Discount Deadline date to receive discounted pricing.

Event Code: M145781120  
 email: [baltimore@shepardes.com](mailto:baltimore@shepardes.com)  
 phone: (410) 737-9270  
 fax: (410) 737-9274

### Bar Tables - All Black Base

### Barstools

Qty.	Item	Discount	Regular	Amount	Qty.	Item	Discount	Regular	Amount
	VTK-30" Maple Top/Black Base	\$383.00	\$497.90			BST-Banana, White/Chrome	\$385.90	\$501.65	
	VTP-36" Maple Top/Black Base	\$409.45	\$532.30			BSS-Banana, Black/Chrome	\$385.90	\$501.65	
	VTJ-30" Graphite Top/Black Base	\$383.00	\$497.90			BS001-Shark, Swivel White	\$491.90	\$639.45	
	VTN-36" Graphite Top/Black Base	\$409.45	\$532.30			BS002-Zoey, Swivel White	\$450.70	\$585.90	
	VTW-36" White Laminate Top	\$409.45	\$532.30			BS003-Zoey, Swivel Black	\$450.70	\$585.90	
	VTB-30" Red Top/Black Base	\$383.00	\$497.90			RSTSTL-Rustique Barstool, Gunmetal	\$223.85	\$291.00	
	30WH42 30" White Laminate,	\$403.60	\$524.70			APS08-Apex Black Vinyl	\$347.60	\$451.90	
	VTA-30" Grey Top/Black Base	\$383.00	\$497.90			APS59-Apex Red Vinyl	\$347.60	\$451.90	
	RSTSQT Rustique Square Metal Bar Table	\$424.20	\$551.45			APS75-Apex White Vinyl	\$347.60	\$451.90	
	30BEBB-Blue Top/Black Base	\$388.30	\$504.80			APS12-Apex Blue Ultra Suede	\$347.60	\$451.90	
	30WDBB-Wood Top/Black Base	\$388.30	\$504.80			XBAR-Christopher White Vinyl	\$279.80	\$363.75	
	30BKSB Black Top/Black Base	\$388.30	\$504.80			LMBAR-Laguna, Maple/Chrome	\$288.65	\$375.25	
	30AGBB Brushed Gunmetal/Black Base	\$388.30	\$504.80			BSR-Syntax, Black/Chrome	\$350.55	\$455.70	
	30YBBB Brushed Yellow/Black Base	\$388.30	\$504.80			ZENBAR-Zenith, White/Chrome	\$259.20	\$336.95	
	30GSBB Green Top/Black Base	\$388.30	\$504.80			BSC-Oslo, White	\$406.50	\$528.45	
	30OSBB Orange Top/Black Base	\$388.30	\$504.80			ROLLBL-Lift Barstool, Black Vinyl	\$327.00	\$425.10	
	36BKHB Black Top/Black Base	\$388.30	\$504.80			ROLLGY-Lift Barstool, Grey Vinyl	\$327.00	\$425.10	
						ROLLRD-Lift Barstool, Red Vinyl	\$327.00	\$425.10	
						ROLLWH-Lift Barstool, White Vinyl	\$327.00	\$425.10	
						BLDBRD-Blade, Red	\$200.85	\$261.10	
						BLDBSB-Blade, Sky Blue	\$200.85	\$261.10	
						LUBSCL- Frosted, Acrylic	\$401.70	\$522.20	

### Bar Tables - Chrome Base 30", Hydraulic

Qty.	Item	Discount	Regular	Amount					
	30GRHB-Graphite Nebula, Chrome	\$465.45	\$605.10						
	30MTHB-Maple Top, Chrome	\$465.45	\$605.10						
	30BRHB-Brushed Red, Chrome	\$465.45	\$605.10						
	30WHHB White Laminate, Chrome	\$503.75	\$654.90						
	30MAHB-Grey Top, Chrome	\$465.45	\$605.10						
	30BEHB-Blue Top, Chrome	\$468.65	\$609.25						
	30WDHB-Wood Top, Chrome	\$468.65	\$609.25						
	30BKHB-Black Top, Chrome	\$468.65	\$609.25						
	30AGHB Brushed Gunmetal, Chrome	\$468.65	\$609.25						
	30YSHB Brushed Yellow, Chrome	\$468.65	\$609.25						
	30GSHB Green Top, Chrome	\$468.65	\$609.25						
	30OSHB Orange Top, Chrome	\$468.65	\$609.25						

### Bars and Counters

	MTBLPI-Midtown Bar, Lighted	\$2,289.70	\$2,976.60	
	MTBUUL-Midtown Bar, unlighted	\$2,142.40	\$2,785.10	
	MTCLPI- Midtown Counter, Lighted	\$2,289.70	\$2,976.60	
	MTCPUL- Midtown Counter, Unlighted	\$2,155.80	\$2,802.55	

### Bar Tables - Chrome Base 36", Hydraulic

	36GRHB-Graphite Nebula, Chrome	\$506.70	\$658.70	
	36MTHB, Maple Top, Chrome	\$506.70	\$658.70	
	36WTHB-White Top, Chrome	\$506.70	\$658.70	
	36BKHB Black Top, Chrome	\$506.70	\$658.70	

Submission of this form indicates you read and accept the Payment Policy and Terms & Conditions.

There are no exchanges or refunds once item has been delivered to your booth. Cancellations must be received in writing within 14 days prior to first exhibitor move in day.

Rental items found and in use in your booth are subject to "Regular" pricing.

Total Bar: \$ \_\_\_\_\_  
 6.000% Tax\*: \$ \_\_\_\_\_  
 Amount Due: \$ \_\_\_\_\_

Company Name: \_\_\_\_\_ Booth # \_\_\_\_\_

Contact Name \_\_\_\_\_

Email: \_\_\_\_\_

Signature: \_\_\_\_\_



AFCEA Belvoir PEO Industry Days

Gaylord National Resort & Convention Ctr (Prince George Exhibits) - National Harbor, MD

November 17 - 18, 2020

Discount Deadline Tuesday, October 27, 2020

Order with complete Payment Authorization must be received before Discount Deadline date to receive discounted pricing.

Event Code: M145781120
email: baltimore@shepardes.com
phone: (410) 737-9270
fax: (410) 737-9274

Desks, Credenzas, Files, Bookcases

Table with 5 columns: Qty., Item, Discount, Regular, Amount. Rows include CR8-Madison Credenza, JD8-Madison Executive Desk, BC8-Madison Bookcase, TECH3B-Tech Desk, TECH-Tech Desk, and TECH3-3-drawer File Cabinet.

Work & Multi-Use Tables

Table with 5 columns: Qty., Item, Discount, Regular, Amount. Rows include MERLIN-Multi Use Table and WD3-Work Table.

Product Display- Shelving

Table with 5 columns: Qty., Item, Discount, Regular, Amount. Row includes PSHCCS-Posh Shelving.

Product Display- Pedestals

Table with 5 columns: Qty., Item, Discount, Regular, Amount. Rows include PDL36B-Ped, PDL42B-Ped, PDL36W-Ped, and PDL42W-Ped.

Lamps

Table with 5 columns: Qty., Item, Discount, Regular, Amount. Rows include LA15-Mason Silver Floor Lamp and LA14-Mason Silver Table Lamp.

Hedge Walls

Table with 5 columns: Qty., Item, Discount, Regular, Amount. Rows include HDG4FT-Boxwood Hedge and HDG7FT-Boxwood Hedge.

Submission of this form indicates you read and accept the Payment Policy and Terms & Conditions.

There are no exchanges or refunds once item has been delivered to your booth. Cancellations must be received in writing within 14 days prior to first exhibitor move in day.

Rental items found and in use in your booth are subject to "Regular" pricing.

Total Exec Accessories: \$
6.000% Tax\*: \$
Amount Due: \$

Company Name: Booth #

Contact Name

Email:

Signature:

# ELEVATE YOUR EXHIBIT

With Shepard, You Can.

## What are your exhibit goals?

Whether you're new to the exhibits space or a seasoned pro, Shepard's here to help. We're your go-to exhibits partner.

- Bring our brand to life
- Create an engaging experience
- Attract attention
- Make exhibiting easy
- Generate traffic



### High-impact exhibits

Whatever your needs (or budget), Shepard's got you covered.

- **Custom Fabrication**, for a signature look & feel
- **Custom Rental**, for ultimate flexibility
- **Fabric Panels**, for maximum ease



### Offering innovative exhibit frameworks ... and more

- Graphic design & printing
- Equipment & furnishings
- Audio visual
- Logistics



### Why Shepard?

- **Complimentary consultation:** We listen, we strategize—and propose on-target ideas
- **Blue Diamond customer service:** Fast, courteous, thoughtful—Shepard's there for you
- **Smart, strategic solutions:** Shepard delivers exhibits that engage your audiences



## Ready to get started?

Contact Our Exhibits Team!  
Exhibits@shepardes.com  
404-720-8600

[shepardes.com](http://shepardes.com)

## AFCEA Belvoir PEO Industry Days

Gaylord National Resort & Convention Ctr (Prince George Exhibits) - National Harbor, MD

November 17 - 18, 2020

**Order Deadline Monday, October 19, 2020**

Order with full payment and graphic files must be received by Order Deadline Date above. Orders received after this date may not be available.

Event Code: M145781120  
 email: [exhibits@shepardes.com](mailto:exhibits@shepardes.com)  
 phone: 404-720-8652  
 fax: 404-720-8757

### Turnkey Rental Designs Make Exhibiting Easier!

Don't See what you are looking for or need a tweak to a design?  
 Let one of our incredible designers create a space just for you! Contact an Exhibits team member to get started!

#### The Eddie

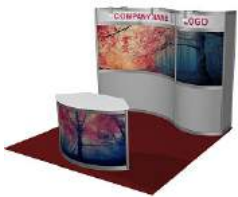

#### The Jonathon



#### The Pierce



#### The Madison



Code	Qty	Item	Discount	Regular
66470		The Eddie- 10' x 10'	\$4,141.20	\$5,383.55
66471		The Eddie- 10' x 20'	\$6,743.70	\$8,766.80
66474		The Jonathon - 10' x 10'	\$2,889.05	\$3,755.75
66475		The Jonathon - 10' x 20'	\$5,057.00	\$6,574.10

Code	Qty	Item	Discount	Regular
66477		The Pierce - 10' x 10'	\$3,583.50	\$4,658.55
66478		The Pierce - 10' x 20'	\$6,804.15	\$8,845.40
66484		The Madison - 10' x 10'	\$4,345.65	\$5,649.35
66485		The Madison - 10' x 20'	\$5,150.35	\$6,695.45

#### The Grant



#### The Harrison



#### The Hamilton

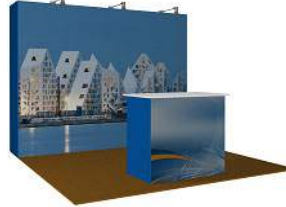

#### The Lucy



Code	Qty	Item	Discount	Regular
66486		The Grant- 10' x 10'	\$4,587.00	\$5,963.10
66487		The Grant- 10' x 20'	\$6,357.45	\$8,264.70
66492		The Harrison - 10' x 10'	\$4,216.90	\$5,481.95
66493		The Harrison - 10' x 20'	\$6,196.45	\$8,055.40

Code	Qty	Item	Discount	Regular
66467		The Hamilton- 10' x 10'	\$2,938.45	\$3,820.00
66468		The Hamilton- 10' x 20'	\$5,147.80	\$6,692.15
66473		The Lucy - 10' x 10'	\$2,655.65	\$3,452.35

Carpet and Electricity not included. Please order as needed. All Exhibit Booth Rentals include installation/dismantling and graphic panels as shown for print-ready graphics. If graphics submitted are not print-ready, additional fees may apply. Monitor and lighting options available. Please contact the Exhibits Department with any questions at 404-720-8652.

Submission of this form indicates you read and accept the Payment Policy and Terms & Conditions.

All orders cancelled by the exhibitor within 30 days of first day of exhibitor move in day may be subject to cancellation fees up to 100% of the total order, based upon the status of move-in, work performed and/or Shepard set-up costs or expenses. \* All tax rates are subject to change.

Total Inline Rentals: \$ \_\_\_\_\_  
 6.000% Tax\*: \$ \_\_\_\_\_  
 Amount Due: \$ \_\_\_\_\_

Company Name: \_\_\_\_\_ Booth # \_\_\_\_\_

Contact Name \_\_\_\_\_

Email: \_\_\_\_\_

Signature: \_\_\_\_\_

## AFCEA Belvoir PEO Industry Days

Gaylord National Resort & Convention Ctr (Prince George Exhibits) - National Harbor, MD

November 17 - 18, 2020

**Order Deadline Monday, October 19, 2020**

Order with full payment and graphic files must be received by Order Deadline Date above. Orders received after this date may not be available.

Event Code: M145781120  
 email: [exhibits@shepardes.com](mailto:exhibits@shepardes.com)  
 phone: 404-720-8652  
 fax: 404-720-8757

## Choose Your Counter & Customize to Fit Your Exhibit!

Color choices for all products Metal Colors Black (06) Silver (15) Panel Colors Black (06) White (03)

### Locking Cabinets

LC1 1Meter Wide



LC2 1.5 Meters Wide



LC3

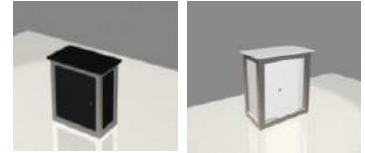

Code	Qty	Item	Product Size	Discount	Regular	Metal Color	Panel Color
66282		LC1	3' 6" L x 3' 6" H x 1' 9" D	\$1,018.15	\$1,323.60		
66283		LC2	5' L x 3' 6" H x 1' 9" D	\$1,235.50	\$1,606.15		
66284		LC3	3' 9" L x 3' 6" H x 2' 3" D	\$751.00	\$976.30	Silver Only	

### Reception Counters

RC2



RC3



Code	Qty	Item	Product Size	Discount	Regular	Metal Color	Panel Color	Graphic Size:
66275		RC2	4' 9"L x 2' 3"D x 3' 3"H x 2' 3"D	\$1,047.00	\$1,361.10			Contact Us to Customize
66276		RC3	5' 3"L x 3' 6"H x 3' 3"D	\$2,271.25	\$2,952.65			1075mm x 885mm

### Computer Stands-Silver Metal Only (graphic included!)

CS1

CS2

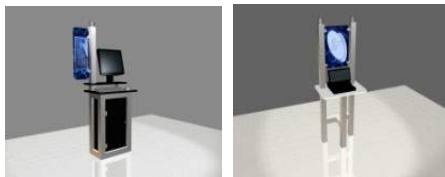

Code	Qty	Item	Product Size	Discount	Regular	Panel Color	Graphic Size
66285		CS1	3' L x 6' 3" H x 1' 9" D	\$1,320.80	\$1,717.05		250mm x 700mm
66286		CS2	2' 3" L x 6' 3" H x 1' 6" D	\$769.85	\$1,000.80		380mm x 580mm

Submission of this form indicates you read and accept the Payment Policy and Terms & Conditions.

All orders cancelled by the exhibitor within 30 days of first day of exhibitor move in day may be subject to cancellation fees up to 100% of the total order, based upon the status of move-in, work performed and/or Shepard set-up costs or expenses. \* All tax rates are subject to change.

Total Counter Rentals: \$ \_\_\_\_\_  
 6.000% Tax\*: \$ \_\_\_\_\_  
 Amount Due: \$ \_\_\_\_\_

Company Name: \_\_\_\_\_ Booth # \_\_\_\_\_

Contact Name: \_\_\_\_\_

Email: \_\_\_\_\_

Signature: \_\_\_\_\_

## AFCEA Belvoir PEO Industry Days

Gaylord National Resort & Convention Ctr (Prince George Exhibits) - National Harbor, MD

November 17 - 18, 2020

**Order Deadline Monday, October 19, 2020**

Order with full payment and graphic files must be received by Order Deadline Date above. Orders received after this date may not be available.

Event Code: M145781120  
 email: [exhibits@shepardes.com](mailto:exhibits@shepardes.com)  
 phone: 404-720-8652  
 fax: 404-720-8757

## Choose Your Unit & Customize to Fit Your Products!

Color choices for showcase and displays Metal Colors Black (06) Silver (15)

Panel Colors Black (06) White (03)

### Product Displays

Gondolas



GL Display Units



Code	Qty	Item	Product Size	Discount	Regular	Metal Color	Panel Color	Graphic Size
66277		Gondola	3' 6" L x 1' 9" D x 5' H	\$713.45	\$927.50			NA
66278		GL1	5' 4" L x 8' H x 1' 3" D	\$705.25	\$916.85	Silver Only	NA	674mm x 1682mm
66279		GL2	4' 3" L x 7' H x 1' 3" D	\$1,215.70	\$1,580.40	Silver Only	NA	674mm x 1682mm

### Showcases

Quarterview

Square



Code	Qty	Item	Product Size	Discount	Regular	Metal Color	Panel Color
66270		Qtrview	4' 6" L x 1' 9" D x 3' 3" H	\$1,373.65	\$1,785.75		
66272		Square	1' 9" L x 1' 9" D x 7' H	\$1,482.60	\$1,927.40		

### Charging Units

Code	Qty	Item	Product Size	Discount	Regular	Panel Color	Graphic Size
66430		PCS	3' L x 6' 3" H x 1' 9" D	\$2,333.75	\$3,033.90	Black Only	250mm x 700mm

PCS



### Perforated/Peg Boards

Code	Qty	Item	Product Size	Discount	Regular
66148		PerfH	4'x7' Pegboard panel	\$346.85	\$450.90
66149		PerfV	4'x8' Pegboard panel	\$346.85	\$450.90
50104		6" Pegs	6" Pegs 1 dozen	\$56.60	\$73.60
66147		Slatwall	8'x3.5' Slatwall grey vert	\$346.85	\$450.90

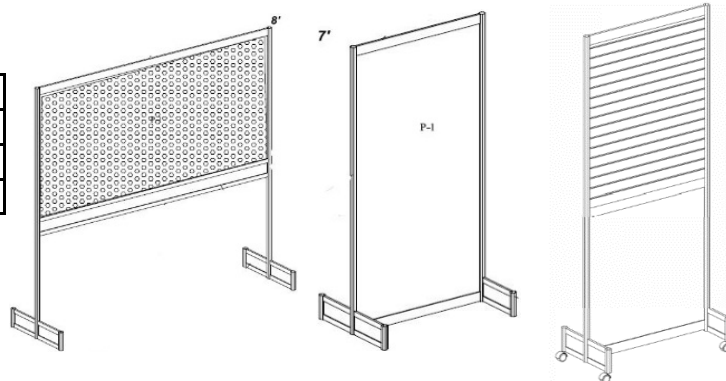

Submission of this form indicates you read and accept the Payment Policy and Terms & Conditions. Custom Product Display Rentals: \$ \_\_\_\_\_  
 All orders cancelled by the exhibitor within 30 days of first day of exhibitor move in day may be subject to cancellation fees up to 100% of the total order, based upon the status of move-in, work performed and/or Shepard set-up costs or expenses. \* All tax rates are subject to change. 6.000% Tax\*: \$ \_\_\_\_\_  
 Amount Due: \$ \_\_\_\_\_

Company Name: \_\_\_\_\_ Booth # \_\_\_\_\_  
 Contact Name \_\_\_\_\_  
 Email: \_\_\_\_\_  
 Signature: \_\_\_\_\_



**AFCEA Belvoir PEO Industry Days**

Gaylord National Resort &amp; Convention Ctr (Prince George Exhibits) - National Harbor, MD

November 17 - 18, 2020

**Order Deadline Monday, October 19, 2020**

Order with full payment and graphic files must be received by Order Deadline Date above. Orders received after this date may not be available.

 Event Code: M145781120  
 email: [exhibits@shepardes.com](mailto:exhibits@shepardes.com)  
 phone: 404-720-8652  
 fax: 404-720-8757

**10x10 Fabric Booth Rental Display**

Code	Qty	Item	Discount	Regular
66557		FX21 10' x 10'	\$2,730.70	\$3,549.90
66558		FX2M1 10' w/Monitor	\$4,940.05	\$6,422.05

Side panel colors are either white or black

Backwall graphic size 3042mm x 2432mm

Counter graphic size 1070mm x 1020mm

Monitor 66620

Code	Qty	Item	Discount	Regular
66561		FX2H1 10' x 10'	\$3,341.40	\$4,343.80
66562		FX2M1H 10' w/Monitor	\$5,550.75	\$7,216.00

Side panel colors are either white or black

Backwall graphic size 3042mm x 2432mm

Counter graphic size 1070mm x 1020mm

Header graphic size 2440mm x 380mm

Monitor 66620

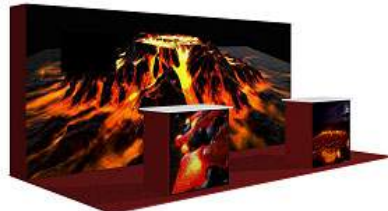
**10x20 Fabric Booth Rental Display**

Code	Qty	Item	Discount	Regular
66559		FX22 10' x 20'	\$4,733.30	\$6,153.30
66560		FX2M2 10' x 20' w/Monitor	\$6,942.65	\$9,025.45
66567		FX2H2 10' x 20'	\$5,279.50	\$6,863.35
66563		FX2M2H 20' w/Monitor	\$7,488.85	\$9,735.50

Side panel colors are white or black

Backwall graphic size 6012mm x 2432mm

Counter graphic size 1070mm x 1020mm

Header graphic size 2440mm x 380mm

Monitor 66620

**\*\*Please Note\*\*** Carpet is not included, to order please refer to the Carpet Order form.

All Exhibit Booth Rentals include installation/dismantling and graphic panels as shown for print-ready graphics. If graphics submitted are not print-ready, additional fees may apply. Monitor and lighting options available. Please contact a Exhibit Team member with any customization requests at 404-720-8652.

 Submission of this form indicates you read and accept the Payment Policy and Terms & Conditions.  
 All orders cancelled by the exhibitor within 30 days of first day of exhibitor move in day may be subject to cancellation fees up to 100% of the total order, based upon the status of move-in, work performed and/or Shepard set-up costs or expenses. \* All tax rates are subject to change.

 Total Fabex Rental: \$ \_\_\_\_\_  
 6.000% Tax\*: \$ \_\_\_\_\_  
 Amount Due: \$ \_\_\_\_\_

 Company Name: \_\_\_\_\_ Booth # \_\_\_\_\_  
 Contact Name \_\_\_\_\_  
 Email: \_\_\_\_\_  
 Signature: \_\_\_\_\_

## AFCEA Belvoir PEO Industry Days

Gaylord National Resort & Convention Ctr (Prince George Exhibits) - National Harbor, MD

November 17 - 18, 2020

**Order Deadline Monday, October 19, 2020**

Order with full payment and graphic files must be received by Order Deadline Date above. Orders received after this date may not be available.

Event Code: M145781120  
 email: [exhibits@shepardes.com](mailto:exhibits@shepardes.com)  
 phone: 404-720-8652  
 fax: 404-720-8757

### Freestanding 8' high Backlit Backwalls with Full Color Graphics

#### FX 11- 8'h x 10'



**Step 1:** Choose Your Booth Size  
**Step 2:** Send Us Your Full Color Graphics

Code	Qty	Item	Discount	Regular	Graphic Sizes
66564		FX11 10' x 10' Backlit	\$2,753.55	\$3,579.60	3042mm x 2436mm
66565		FX12 10' x 20' Backlit	\$4,255.40	\$5,532.00	6088mm x 2436mm
66566		FX13 10' x 30' Backlit	\$5,757.30	\$7,484.50	8992mm x 2436mm

**Carpet/Flooring, Furnishings, Power and Accessories not included.**

#### FX 12- 8'h x 20'

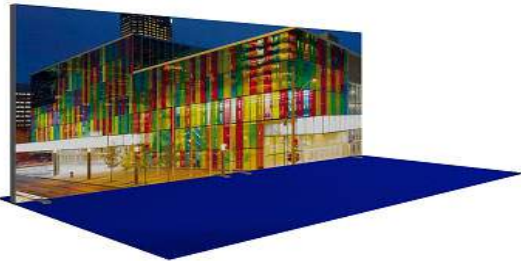

#### FX 13- 8' h x 30'



All Exhibit Booth Rentals include installation/dismantling and graphic panels as shown for print-ready graphics. If graphics submitted are not print-ready, additional fees may apply. Monitor and lighting options available. Please contact an Exhibits team member with any questions at 404-720-8652.

Submission of this form indicates you read and accept the Payment Policy and Terms & Conditions.

All orders cancelled by the exhibitor within 30 days of first day of exhibitor move in day may be subject to cancellation fees up to 100% of the total order, based upon the status of move-in, work performed and/or Shepard set-up costs or expenses. \* All tax rates are subject to change.

Total Fabex Backlit: \$ \_\_\_\_\_  
 6.000% Tax\*: \$ \_\_\_\_\_  
 Amount Due: \$ \_\_\_\_\_

Company Name: \_\_\_\_\_ Booth # \_\_\_\_\_  
 Contact Name \_\_\_\_\_  
 Email: \_\_\_\_\_  
 Signature: \_\_\_\_\_

### **LABOR**

Maryland is NOT a “right-to-work” state. The installation and dismantling of prefabricated displays comes under the jurisdiction of the Carpenters union. Union Labor is available to assist in the installation and dismantling of exhibit booths. Exhibit labor, freight and rigging labor, electricians and plumbers can be arranged for at established rates, using the enclosed order forms.

### **EXHIBIT LABOR JURISDICTION**

Carpenter union exhibit labor claims jurisdiction for the installation, dismantling, and first cleaning of prefabricated exhibits and displays. However, two (2) full-time exhibiting company employees may work without Carpenter Labor for one (1) hour on the installation (move in) and (1) one hour on the dismantle (move out), without union labor on booths that are larger than 10x10. Exhibitors may work in booths 10x10 or smaller without the use of union labor.

Exhibitors are not permitted to use Power Tools (electric drills, power saws, etc.) on booths of any size. Manual tools such as hammers, screwdrivers, ratchets, pry bars, etc. are allowable for exhibitor use within the size and time frame limitation. Exhibitors may not borrow tools, ladders or other equipment from the exhibit facility or from Shepard Exposition Services.

### **MATERIAL/FREIGHT HANDLING JURISDICTION**

Shepard Exposition Services has the responsibility of receiving and handling all exhibit materials and empty crates that comes in via over the road carriers. It is Shepard’s responsibility to manage docks and schedule vehicles for the smooth and efficient move-in and move-out of the exhibition. Shepard will not be responsible, however, for any materials they do not handle. Unloading or reloading of any freight into the exhibit hall by any and all private vehicles and contracted carriers will be handled by Shepard Exposition Services. Rates for material handling services are enclosed in this exhibitor service manual.

One individual from each exhibiting company is permitted one trip to hand carry items into exhibit facility. The use of dollies, hotel baggage carts, flat trucks, and other mechanical equipment is not permitted.

Vehicles must not be left unattended at the loading areas. Any unattended vehicles will be towed at the owner’s expense.

The Fire Marshal absolutely prohibits the storage of empty containers in the exhibit hall. Arrangements have been made with Shepard Exposition Services to store empty crates. Please refer to the Material Handling Information sheet in this service manual for the handling of empties, disposal of skids, etc.

### **GRATUITIES /BREAKS**

Tipping is expressly prohibited. This includes such practices as giving money, merchandise, or other special consideration for services rendered. Do not give coffee breaks other than mid-morning and mid-afternoon, when the union has a 15-minute paid break. Meal breaks are one hour. Any attempt to solicit a gratuity by an employee for any service should be reported immediately to Shepard Exposition Services.

### **IN GENERAL**

Exhibitors do not have to respond to grievances or complaints from union and trade personnel with respect to work jurisdictions. Please refer all such disputes and/or questions to Shepard management personnel immediately.

### **SAFETY**

Safety of everyone working in the hall is of our utmost concern at all times. Standing on chairs, tables and other rental furniture is prohibited. This furniture is not engineered to support your standing weight. Shepard Exposition Services cannot be held responsible for injuries or falls caused by the improper use of this furniture. If assistance is required in assembling your booth, please order labor on the Labor Order Form included in this manual and the necessary ladders and tools will be provided.



AFCEA Belvoir PEO Industry Days

Gaylord National Resort & Convention Ctr (Prince George Exhibits) - National Harbor, MD

November 17 - 18, 2020

Event Code: M145781120
email baltimore@shepardes.com
phone (410) 737-9270
fax (410) 737-9274

Discount Deadline Tuesday, October 27, 2020

Order with complete Payment Authorization must be received before Discount Deadline date to receive discounted pricing.

Labor Hours

ST - Straight time: Monday - Friday 8AM - 5PM.
OT - Overtime: Monday - Friday 5PM - 8AM. All hours Saturday and Sunday.
DT - Double-time: Holidays.

Table with 4 columns: Code, Discount, Regular, Estimate. Rows for codes 68066, 68067, 68068.

Table with 4 columns: Code, Discount, Regular, Estimate. Rows for codes 68070, 68071, 68072.

Booth Size: X

\*\*Pricing includes Supervisory fee of 30% over standard labor .

Step One:

Choose Your Service

- Installation
Dismantling
Both

Step Two:

How Many People?

- #
#
#

Step Three:

How Many Hours?

- #
#
#

Step Four:

When Should the Build be Complete?

- Date: Time:
Date: Time:
Date: Time:

Step Five: Tell Us About Your Exhibit! (this portion must be completed before Shepard can begin any work on your exhibit)

Inbound Freight Advance Warehouse Direct to Show site

Carrier Name Tracking or Pro #
Estimated Arrival Date # of Pieces Estimated Weight

Set Up Information:

Company Contact Name:
Email
Cell Phone #

Drawings/Photos/ Instructions:

- Attached
Emailed to Shepard
With the Exhibit
In crate #

Graphics:

- With Exhibit
Shipped Separately

Electrical Placement

(exhibitor is responsible to order)

- Emailed to Shepard
Drawing Attached
Drawing with Exhibit
Run under carpet

Other Services Ordered:

- Overhead Rigging
Cleaning
AV

Carpet:

- Ordered from Shepard
Exhibitor Owned Carpet
Carpet Padding

Outbound Shipping:

# of Crates
# of Cartons
# of Fiber Cases
# of Pallets

Method:

- Ground
2-Day Air
Next Day Air
Other

Phone #

Must Arrive at Destination By:

Name of Carrier

Date Carrier is Scheduled to Pick Up Freight

If Your Carrier doesn't show? Reroute with SLS
Send to advance warehouse for pick up (\$400 minimum charge)

\*Allow time for empty return when scheduling your pick up

Hours are based on estimates. You will be invoiced for actual time incurred. Minimum one hour per person ordered and half increments thereafter.

Orders cancelled without 48-hour written notice will be charged a one (1) hour cancellation fee.

Estimated SES Blue Labor: \$
6.000% Tax\*: \$
Amount Due: \$

Company Name: Booth #
Contact Name
Email:
Signature:



# Exhibitor Supervised Labor

## AFCEA Belvoir PEO Industry Days

Gaylord National Resort & Convention Ctr (Prince George Exhibits) - National Harbor, MD

November 17 - 18, 2020

### Discount Deadline Tuesday, October 27, 2020

Order with complete Payment Authorization must be received before Discount Deadline date to receive discounted pricing.

#### Labor Hours

ST - Straight time: Monday - Friday 8AM - 5PM.  
OT - Overtime: Monday - Friday 5PM - 8AM. All hours Saturday and Sunday.  
DT - Double-time: Holidays.  
Holidays:

**Exhibitors may not operate any type of mechanical or powered equipment.**

Event Code: M145781120

email [baltimore@shepardes.com](mailto:baltimore@shepardes.com)

phone (410) 737-9270

fax (410) 737-9274

### Exhibitor Supervised Install Labor

Code		Discount	Regular	Estimate
68060	ST	\$120.75	\$157.00	
68061	OT	\$181.13	\$235.45	
68062	DT	\$241.50	\$313.95	

### Exhibitor Supervised Dismantle Labor

Code		Discount	Regular	Estimate
68063	ST	\$120.75	\$157.00	
68064	OT	\$181.13	\$235.45	
68065	DT	\$241.50	\$313.95	

#### Step One:

Choose your service

- Installation
- Dismantling
- Both

#### Step Two:

How many people?

- # \_\_\_\_\_
- # \_\_\_\_\_
- # \_\_\_\_\_

#### Step Three:

How many hours?

- # \_\_\_\_\_
- # \_\_\_\_\_
- # \_\_\_\_\_

#### Step Four:

Carpet:

- Ordered from Shepard
- Exhibitor Owned Carpet
- Carpet Padding

#### Step Five:

Any other details?

Any special tools needed? Ladders? Lifts?

- Ladders
- Lifts
- Special Tools: \_\_\_\_\_

Details: \_\_\_\_\_

#### Step Six: Schedule

	Date	Start Time	End Time
Installation Request			
Dismantle Request			

Requested times are not guaranteed and are based on availability.

#### Step Seven: Onsite Contact Info

Name: \_\_\_\_\_

Cell: \_\_\_\_\_

Email: \_\_\_\_\_

Hours are based on estimates. You will be invoiced for actual time incurred. Minimum one hour per person ordered and half increments thereafter.

Orders cancelled without 48-hour written notice will be charged a one (1) hour cancellation fee.

Labor Estimate \$ \_\_\_\_\_  
 6.000% Tax\*: \$ \_\_\_\_\_  
 Amount Due: \$ \_\_\_\_\_

Company Name: \_\_\_\_\_ Booth # \_\_\_\_\_

Contact Name: \_\_\_\_\_

Email: \_\_\_\_\_

Signature: \_\_\_\_\_